

AN1808-01 (ACCESS CONTROL SYSTEM)

OPERATING MANUAL



For your protection, read these instructions completely

And keep them for future reference.

TABLE OF CONTENTS

Important Safety Instructions.....	3
Introduction.....	4
Parts List	4
Installation.....	5
Wiring Diagram	8
Using the AN1808-01	9
1. Setting your call out numbers	9
2. Setting your dial in numbers	9
3. App on iOS and Android	9
Enter System Menu.....	10
Programming by text message	11
SMS/ Phone mode code	12
Command Codes.....	12
SMS Inquire	15
E-mail settings.....	16
How To Change The Name Plate.....	17
Hardware reset (if you forget password).....	18
Troubleshooting (Q &A).....	18
Specification:	20

Thank you for purchasing AN1808-01 4G/3G audio intercom. Please read this manual carefully before using.

Be sure to keep this manual for future reference in case of any problem or question should arise.

Important Safety Instructions

When using this AN1808-01 4G/3G audio intercom, basic safety precautions should always be followed to reduce the risk of fire, electric shock and personal injury. Please read the following before using your equipment.

1. Follow all warning and instructions on the product.
2. Unplug all the connections of product before cleaning. Do not use liquid cleaners or aerosol cleaners. Use a damp cloth for cleaning.
3. Do not use this product near water.
4. Do not use this product near an area where there is a potential of gas leaks or near any fumes that can be explosive.
5. Do not place this equipment near or over a radiator or any other heat source.
6. Do not overload the wall outlet or power cord where the power adapter is installed. This can result in fire or electric shock
7. Avoid spilling liquid on this equipment and do not insert any objects through the ventilation slots.
8. Avoid using the equipment during an electrical storm. There is a remote risk of electrical shock from lightning.

Introduction

When the visitor press "call button" (📞) on the intercom which will then call to your phone number whatever landline or mobile, once you answer the call then you can speak with visitor and you can open the gate from your phone remotely from anywhere anytime.

The AN1808-01 is also Access Control System to let users open the gate with their phone number remotely. You need to program the phone numbers of all users into the dial-to-open numbers of device before using. When the user call to the SIM card number in the device which will check if the calling number is match in the dial-to-open numbers then open your gate.

The device installation is very easy so you don't need to spend extra installation fee. To wire with your gate or garage systems and power, no special installation or complicated wiring is necessary.

Take an active SIM card to start.

Mounting Bracket

Parts List

Item	Description	Q'ty
1	AN1808-01 4G/3G audio intercom	1
2	Power adapter	1
3	External 3-meter antenna	1
4	Mounting Bracket for antenna	1
5	Operating manual	1
6	6 Pin Cable	1
7	Terminal Blocks	1

Accessories

Terminal Blocks

6 Pin Cable

Power Cable

Antenna

Mounted Bracket

Power Adapter



Installation

This 4G/3G audio intercom is suitable for both flush mounting and surface mounting.

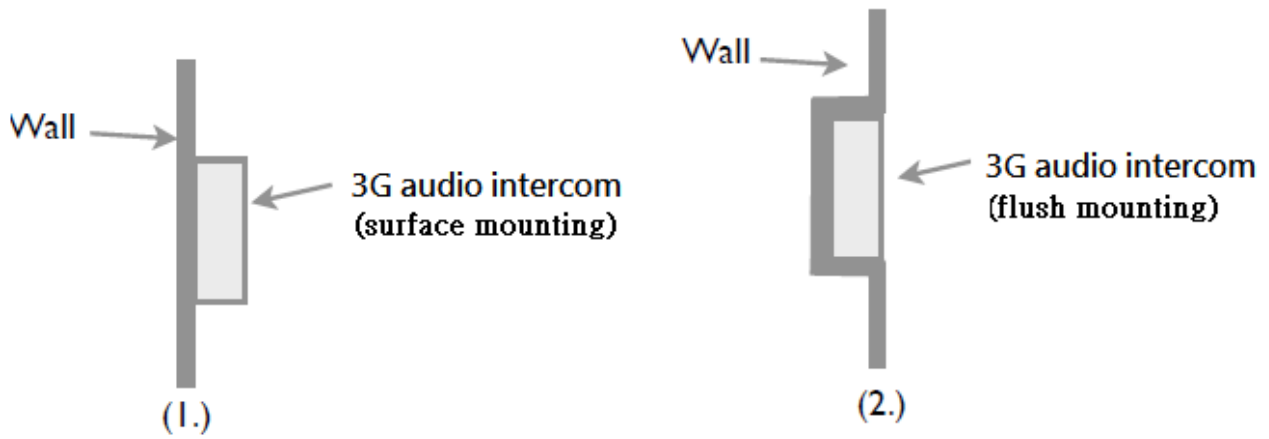

Front View



1. SIM card installation (Fig 1)

- 1.1 Disconnect the 12V adaptor from the AN1808-01
- 1.2 Remove the rear plastic cover
- 1.3 Remove the SIM card cover from the bottom of the unit
- 1.4 Slide the SIM card holder towards the front of the unit
- 1.5 Lift up the holder
- 1.6 Before inserting the SIM card, ensure that it is not PIN number locked. (If locked, use a mobile phone to unlock it).**
- 1.7 Insert the SIM card (Note orientation of notched corner)
- 1.8 Replace holder and slide towards the rear of the unit to lock in place
- 1.9 Replace rear plastic cover



2. Connecting with the door lock system (Fig 2)

2.1 According your door lock type to wire with door latch of connector.

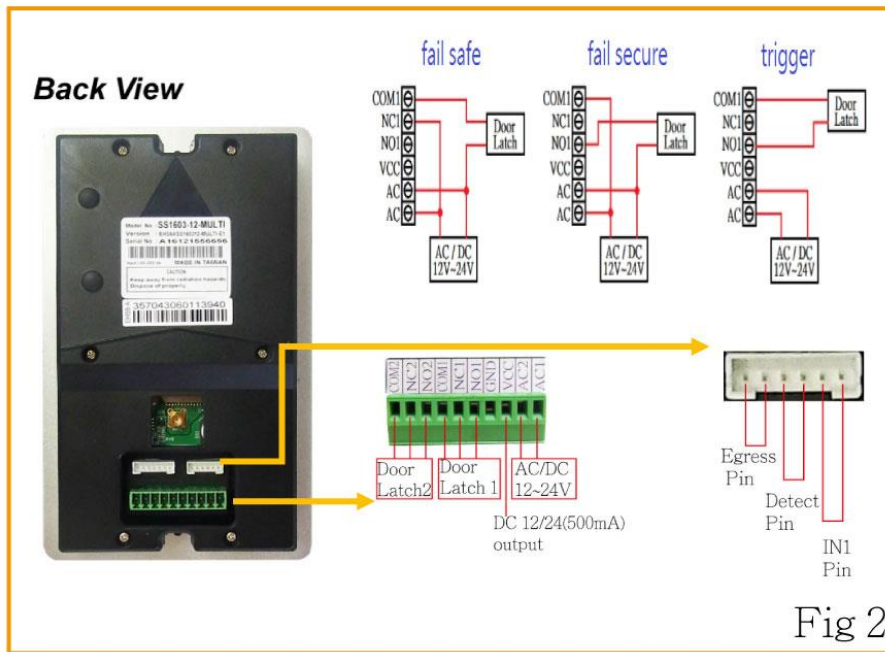

3. Connecting the Antenna (Fig 3)

3.1 Plug on the antenna cord to the connector on the rear of the unit

3.2 Place antenna away from electrical/electronic systems (computers, microwave ovens, etc)

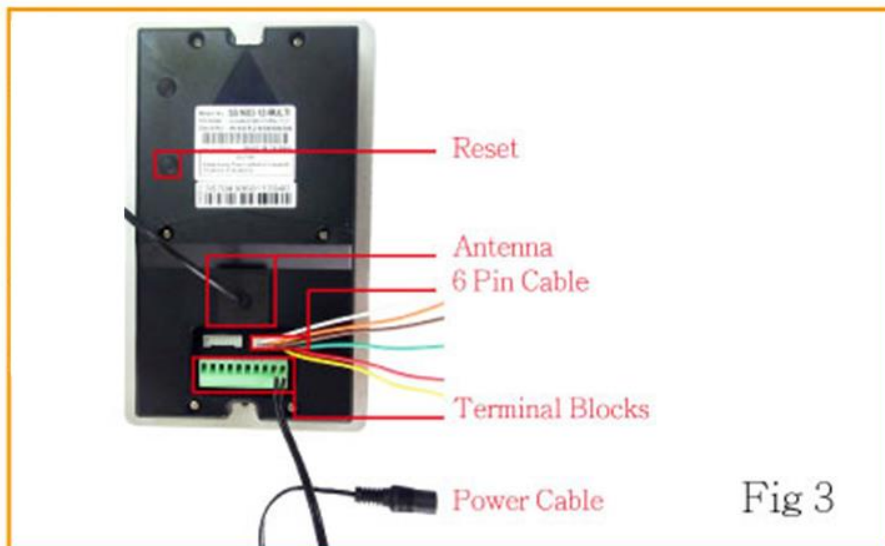

4. Power on and Fix it well

- 4.1 Connect the power adaptor into the connector marked AC
- 4.2 The blue indicator of call button should be on and you will hear Du Du tone.
- 4.3 Fix the unit on the position before ready.
- 4.4 When the Du Du tone is disappeared then the Device is ready.

Wiring Diagram

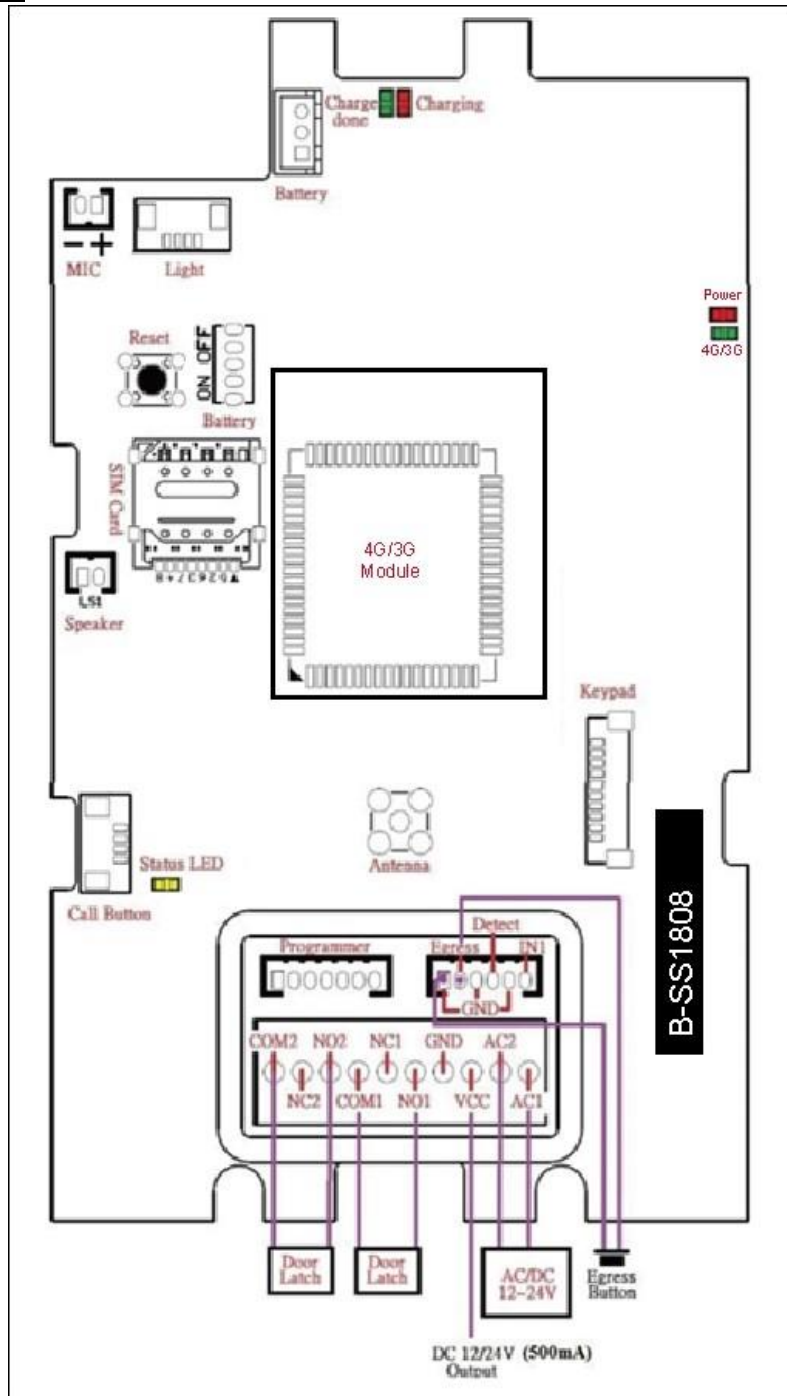

Using the AN1808-01

1. Setting your call out numbers

1.1 Send the text SMS to the number of device.

1.2 The format of text SMS is

***12*1234#11[call out number 1]#12[call out number 2]#13[call out number 3]#**

1.3 When the setting is finished, the sender will receive the reply as below.

11[call out number 1]#12[call out number 2]#13[call out number 3]#OK

1.4 If you press call button of device, it will call to the numbers in sequence.

2. Setting your dial in numbers

2.1 Send the text SMS to the number of device.

2.2 The format of text SMS is

***12*1234#71[country code]#72[relay][call in number 1]# 72[relay][call in number 2]#...**

2.3 When the setting is finished, the sender will receive the reply as below.

71[country code]#72[relay][call in number 1]# 72[relay][call in number 2]#...OK

2.4 If you call to the number of device through the dial in numbers, the device will trigger the relay to control the door latch.

2.5 If the number is not matched with the dial in numbers, the device will answer and sound a beep. Then you can enter the programming mode by password.

3. App on iOS and Android

3.1 Please search “**3G intercom**” on Apple store or Google Play

3.2 The App can help you to program the device easier.

3.3 You can use the App to unlock the door through call or SMS.

Enter System Menu

1. Please call the number of the 4G/3G intercom device.
2. The device will answer and sound one beep to enter system menu.
3. Enter the password of the mode you would like to enter.
 - 3.1 Listener monitoring mode. 【*13*1212 #】
 - 3.2 Access control mode 【*33*5678 #】
 - 3.3 Program setting mode 【*12* 1234 #】
4. Password correct one beep, password error 3 beeps.
5. 3 times failure attempt on password, the device hang up the call.

Enter Listener Monitoring Mode

1. You will hear a “Do” tone to enter listener monitoring mode by pressing 【*13*1212 #】 where 1212 is the monitoring password.
2. Then you can hear the live sound of the device’s surrounding environment.
 - * Under this mode speaker is OFF. (35 # : To turn on speaker)
 - * You can still control the relay output under listener monitoring mode but speaker must be ON status.

Enter Access Control Mode

1. You will hear a “Do” tone to enter access control mode by pressing 【*33*5678 #】 where 5678 is the access control password.
2. The door will be opened after enter the correct password
 - *(To open the door by password, if the number is not stored in the access control section)

Enter Program setting Mode

1. You will hear a “Do” tone to enter into program setting mode by pressing 【*12* 1234 #】 where 1234 is the setting password.
2. You are now in the “program setting mode”

**Note: At the end of each command there can be one of the two indications:
Successful: a long “beep” tone, failed: three short “beep” tone.**
3. To make changes on settings please refer to the command codes in page 12.
4. To end program setting mode just hang up.

NOTE:

***To be successful in programming, originate a call from a land line and enter the digits slowly or using programming by text message.**

Programming by text message

Programming by text message is the simplest way to customize the settings of the 4G/3G audio intercom and add or delete telephone numbers. Simply send texts in the format to the telephone number of the SIM within the 4G/3G audio intercom.

Note:

1. A Single SMS text messages is limited to 140 characters.
2. You can program many different user command codes in one text message with SMS command format. ***12*1234 # [command Code1] # [command Code 2] # [command Code3] #...**
3. Each SMS must start with the pass code , default 1234 in the following format ***12*1234 #** followed immediately by a command.
4. To program a call button numbers DO NOT enter country code, just the complete number as you would dial it.

Example:

Store a call button phone number (Max 3 numbers) and delete 2&3 phone numbers.

058 57235 (landline number 1)

086 5682554 (mobile number 2)

086 2235644 (mobile number 3)

Command to use: *12*1234#1| Y|[phone number]#

Y= number 1, 2 or 3

SMS format: (store a call button phone numbers)

***12*1234#1105857235#120865682554#130862235644#**

SMS format: (delete 2&3 phone numbers from a call button)

***12*1234#12*#13*#**

User command code CORRECT

SMS format:

***12*1234#1105857235#120865682554#130862235644#**

SMS reply:

1105857235#120865682554#130862235644# OK

User command code ERROR (user command 19 error)

SMS format: ***12*1234#1105857235#190865682554#130862235644#**

SMS reply: **110587235#190865682554# Error**

SMS/ Phone mode code

No.	Feature	Command	NOTE:
1	Setting mode	*12*[setting password]#	<p>Phone mode: Dial the phone and enter *12*1234 to enter the setting mode. (listen to DO), you can enter the command codes below.</p> <p>SMS: You can program many different command codes in one text message with SMS command format. *12*1234 # [command Code 1] # [command Code 2] # [command Code 3] #.....</p>
2	Monitoring mode	*13*[setting password]#	<p>Phone mode: Dial the phone and enter *13*1234 to enter the monitoring mode.</p> <p>SMS: Send SMS (*13*1212#) to the device and the device will call you back</p>
3	Trigger Relay1	*33*[access control password] #	<p>Phone mode: Dial the phone and enter *3(3, 4, 5)*5678 to (trigger, hold, release) relay1.</p> <p>SMS: Send SMS [*3(3, 4, 5)*5678#] to the device and the device will (trigger, hold, release) relay1</p>
4	Hold Relay1	*34*[access control password] #	
5	Release Relay1	*35*[access control password] #	
6	Trigger Relay2	*36*[access control password] #	<p>Phone mode: Dial the phone and enter *3(6, 7, 8)*5678 to (trigger, hold, release) relay2.</p> <p>SMS: Send SMS [*3(6, 7, 8)*5678#] to the device and the device will (trigger, hold, release) relay2</p>
7	Hold Relay2	*37*[access control password] #	
8	Release Relay2	*38*[access control password] #	

Command Codes

You can program many different command codes in one text message with SMS command format.

*12*1234 # [command Code 1] # [command Code 2] # [command Code 3] #.....

No.	Feature	Command	Description	Default
1.	Change setting Password	01 [password] #	password: 4 digits code	1234
2.	Change access control password	02 [password] #	password: 4 digits code	5678
3.	Change monitoring password	03 [password] #	password: 4 digits code	1212
4.	Store or delete call out phone numbers	1 [Y] [phone number] #	Y= phone number 1,2 or 3 Phone number= 3~20 digits (One * can be delay 3 seconds)	None
		1 [Y] * #	Delete phone number1, 2, 3	

ARISTEL NETWORKS

5.	Speaker Volume	3 [speaker volume] #	speaker volume level= 0 ~ 4	3
6.	Microphone Volume	4 [microphone volume] #	microphone volume level= 0 ~ 4	3
7.	Relay 1 Trigger Time	51 [relay1 time] #	Relay 1 time= 1~9999 sec	1
8.	Relay 2 Trigger Time	50 [relay 2 time] #	Relay 2 time= 1~9999 sec	1
9.	Call Divert to next number time	52 [call divert time] #	Call divert time= 10~99 sec	20 sec
10.	Max Call Time	53 [max call time] #	Max call time= 005~999 sec	060 sec
11.	Max Monitoring time	55[duration time] #	duration time= 00 ~ 60 mins 00 (no limit time)	10 mins
12.	Call in mode	65[mode]	mode = 1 Setting mode mode = 2 Call mode mode = 3 Reject mode (caller ID permit)	1
13.	Call in to open the door numbers (Max: 1150 numbers)	71 [country code] #	Country code= 1~3 digits code	None
		72[relay] [phone number] #	Relay= 1 or 2	
		73 [phone number] #	Delete phone number	
		73*#	Delete all phone numbers	
14.	Add administrator phone number	74 [admin number] #	admin number= 3~15 digits (no number no restriction)	None
15.	Dele administrator phone number	74*#	delete admin phone number	None
16.	Call list reply type	84+X#	X=0: no reply X=1: SMS X=2: E-mail Original setting 1 or 2, changing to 0 will delete "Call list" content	0
17.	Call list reply number (type: SMS)	85 [reply number] #	reply number=3~15digits	None
18.	Dele call list reply number	85*#	Dele call list reply number	None
19.	SMS reply notice of Relay status	894[X]#	X=0 (disable SMS reply) X=1 (enable SMS reply)	0
20.	Dial tone volume	898[X]#	X=1~3 (levels)	2
21.	Set Egress Pin output relay	900[X]#	X=0 (relay 1)	0

ARISTEL NETWORKS

			X=1 (relay 2)		
22.	Set Detect pin output relay (Detect Pin is egress mode)	901[X]#	X=0 (relay 1) X=1 (relay 2)	1	
23.	Detect pin on PCB setup	902[X]#	X=0~3 0: disable 1: egress mode (901) 2: trigger 3. resistance=10KΩ(7.5K~13K)	0	
24.	Emitting bleep when correct PIN code entered	903[X]#	X=0 (disable) X=1 (enable)	1	
25.	Intercom moving Detection (Theft Proof)	904[X]#	X=0 (disable) X=1 (enable)	0	
26.	Set Alert phone number (moving & trigger)	905[Y][phone number] #	Y= phone number 1,2 or 3 Phone number=3~15 digits	None	
27.	Enable or disable IN1	907[X]#	X=0 (disable) X=1 (enable)	0	
28.	Change the length of open code	940[X]#	X=1 (1 code open code) X=2 (2 codes open code)	1	
29.	Change open codes of relay 1&2 including trigger / hold / release for independent apartment	93[ABCDEF]#	A,B,C,D,E,F= 0~9 and * A= trigger relay 1 B= hold relay 1 C= release relay 1 D= trigger relay 2 E= hold relay 2 F= release relay 2	1	2
				code	code
				1	10
				1	10
				1	10
				4	40
4	40				
4	40				
30.	Reset	999#	reset default	None	

SMS Inquire (only one format per seal, length limit 140)

No.	Feature	Command	Reply content	
1	Check signal strength	*20#	Operator name, Network Signal Level = X	
			Network: GSM/WCDMA X= 0~31 , 0 : poor 31 : strong	
2	Check device save number	*21#	O+Call out(TEL),...,I+Call in(TEL),.....E(N)	
			O : Call out number I : Call in number E : End N : Next SMS	
3	Check the RELAY status	*22#	Relay1=(status),Relay2=(status),Detect=(Input) ,IN1=(Input)	
			status: hold/release/trigger Input: ON/OFF	
4	Send SMS message (when Detect Pin is triggered)	*26*[password]#[content]	Password=setting password content= up to 100 characters	Detect PIN Trigger
		26[password] #	Query current message content	
5	Send SMS message (when Intercom is moved)	*27*[password]#[content]	Password=setting password content= up to 100 characters	Case open
		27[password]	Query current message content	
6	Send SMS message (when external power is off) (works for inside battery)	*28*[password]#[content]	Password=setting password content= up to 100 characters	Power loss
		28[password]#	Query current message content	
7	Send SMS message (when external power is active) (works for inside battery)	*29*[password]#[content]	Password=setting password content= up to 100 characters	Power active
		29[password]#	Query current message content	
8	Send SMS message (when IN1 is triggered)	*30*[password]#[content]	Password=setting password content= up to 100 characters	IN1 trigger
		30[password]#	Query current message content	

E-mail settings

No.	Feature	Command	
1	GPRS setting	*40*[setting password]#[APN],[AUTH_type],[APN User name],[APN Password]#	
		NOTE: AUTH_type:0: none 1:PAP 2:CHAP	
2	E-mail setting	*41*[setting password] #[type],[SMTP server],[Port],[User name],[Password,E-mail address],[E-mail sender name]	
		NOTE: Type: 1:normal 2:SSL/TLS	
3	Recipient & copy. Can be no set, but (,) to keep	*42*[setting password]# [normal recipient address],[Recipient name],[Carbon Copy recipient],[Recipient name]#	
4	Letter subject	*43*[setting password]#[E-mail subject]#	
5	Query Email Settings	*4(0~3)*[setting password]#	0: GPRS setting 1: E-mail setting 2: Recipient & copy 3. Letter subject
6	Instant return(send Email)	*44*[setting password]#	SUCCESS(Mail sent) FAIL

How To Change The Name Plate

1.

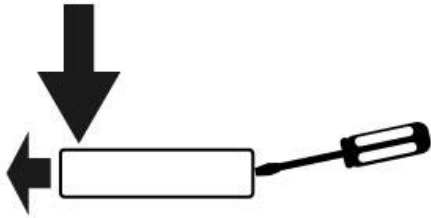

Push the left edge and move to left. Insert the screw driver in the right edge. Turn and push the plastic upwards

2.



Take off the plastic.

3.



Name Plate



Plastic

Change the name plate.

4.



Then insert the left edge into siding.

5.



Push the right edge and move to right

Hardware reset (if you forget password)

1. Keep both reset and egress buttons pressed
2. Release all buttons after you hearing continuous “Dou” tones
3. The device will restart and hardware reset is done

Troubleshooting (Q &A)

Q. The unit keeps bleep.

A. This means the unit is not able to detect the network for some reasons.

-Check the SIM card is activated and has calling credit.

-Power off the unit, remove the SIM and check it in a mobile phone to verify it can make a call.

-Check if the PIN code of SIM disable when put in a phone.

-Check the reception is good. Poor reception is not sufficient.

-Check the antenna has been mounted as high as possible, not near large metal objects, or wet green shrubs etc.

Q. The unit calls the first number, but there is not enough time to answer before it diverts to the next number.

A. Increase the no answer time as per programming instructions.

Q. The unit calls the first number but voicemail comes on before it can ring the second number.

A. Decrease the no answer time as per programming instructions.

Q. The caller ID part does not work.

A. Be sure to program the caller ID part under 72 features. If your number is a private or number withheld, then it will not work.

Even if you have already programmed a number to receive a call from the intercom, if you also want that number to have caller ID access, it must be programmed under the 72 features also.

Ensure the number is entered as you would normally dial it from another phone.

Q. There is no audio from the gate, but the person at the gate can hear ok.

A. This can be due to low reception.

-Check reception level by *20#.

-Change SIM card to another network which may have better coverage.

-Purchase a high gain antenna.

Q. The audio quality that can be heard on the remote telephone is poor or humming (buzzing).

A. A small amount of GSM buzz can be considered normal on 4G/3G audio intercoms, but not so much that causes inability to hear the person speaking. This can be caused by the GSM antenna being mounted too close to the speech panel or not mounted high enough.

-Try earthing the speech panel chassis to 0V of the power supply.

-This is also a symptom of poor reception. Try above steps on checking and improving reception.

Q. The 1 or 2 key does not work when the intercom calls a phone.

A. Check if you can hear the relay clicking at the gate when the 1 or 2 key is pressed during a call. If it can be heard, then the system is working, check wiring between the relay and the lock or gate panel. If the relays do not make a clicking sound, then check this feature on a different mobile cell phone or landline. If it works on a different phone, check the settings on the phone in question under DTMF tones. Failure of DTMF tones to operate correctly is also a symptom of low reception. Check steps above on improving reception. Try pressing the buttons longer when attempting to activate the gates or door.

Specification:

Model	AN1808-01 4G/3G Audio Intercom
Frequency	2G / GSM 850/900/1800/1900 MHz, 3G / WCDMA 800/850/900/1900/2100 MHz 4G / LTE (EC) LTE FDD: B1/B3/B7/B8/B20/B28A 4G / LTE (A) LTE FDD: B2/B4/B12 4G / LTE (AU) LTE FDD: B1/B2/B3/B4/B5/B7/B8/B28 LTE TDD: B40
Face plate	180 (H) x 109 (W) mm
Surface back box	189 (H) x 118 (W) x 65(D) mm
Length of antenna	3 meters cable
Power supply	12~24V AC/ DC
Design and material	Vandal resistant / die cast aluminum
Humidity	Less than 80% RH
Operating Temperature	-20°C to 50°C
Operating Current	Maximum 250 mA, Typically 55mA