

S Touch / S Key

Standalone Access Control

User Manual

1. Introduction, Features and Specifications

1.1 Introduction

The sTouch W-w/ sTouch W-s/ sKey W-w /sKey W-s Standard alone access control realize the card reading and keypad operation functions, lock, alarm, ring bell, exit button and the magnetic contact switch on the door.

The access host supports 125KHz EM, HID cards , 13.56MHz IC and CPU cards (sTouch W-w/sKey W-w), and only 125KHz EM, HID cards (sTouch W-s, sKey W-s)

It controls 1 door, supports up to 2000 users in total, each user have one card and one PIN. The access control unit supports 1 master code, one manager add card, one manager delete card, 1 anti-duress card and 1 anti-duress PIN, providing users with easy operation and safe guarantee.

1.2 Features

- > Aluminium alloy case, waterproof, fully potted, conforms to Ip65
- > Metal keypad(sKey W -w /sKey W-s) and touch panel(sTouch W-w/ sTouch W-s) optional.
- > Built-in 125KHz (EM, HID card) and 13.56MHz(IC, CPU card, ISO14443A) reader.(sTouch W-w, sKey W-w)
- > 125KHz (EM, HID card) reader (sTouch W-s, sKey W-s)
- > Digital backlit key(sKey W-w , sKey W-s) and touch panel (sTouch W-w , sTouch W-s). The back light can be set to Normal ON, Normal OFF or Auto.
- > With door bell function, build-in or external door bell optional.
- > Multi-function, operating as slave reader, single door, anti-pass back function, etc, suitable for various occasions.

1.3 Specifications:

Operating voltage range: DC12-24V

Idle input current: $\leq 35\text{mA}$

Max proximity card read range: EM&HID card: 3-6cm IC&CPU card: 2-6cm

Excitation Frequency: 125KHz and 13.56MHz(sTouch W-w, sKey W-w), 125KHz (sTouch W-s, sKey W-s)

Card transmit format: Wiegand 26-37

Keypad transmit format: 4-6 digits key press to output card number format, 4 bits or 8 bits data.

Access control unit dimensions (Height×Width×Depth): 125×83×21.7mm (sTouch W-w / sKey W-w),
158.6×43×21.7mm (sTouch W-s/ sKey W-s)

Operating temperature range: -40~60° C(EM&HID card), -20~60° C (IC or CPU card)

Operating humidity: 0-95% (non-condensing).

2. Installation and Wiring Diagram

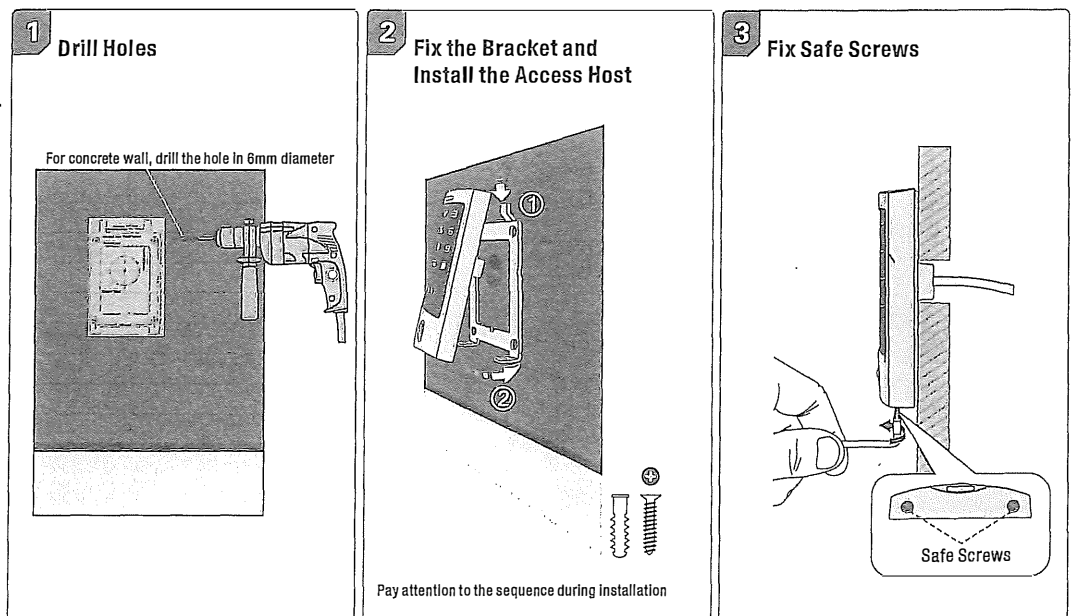

sTouch /sKey Installation

Wiring Diagram

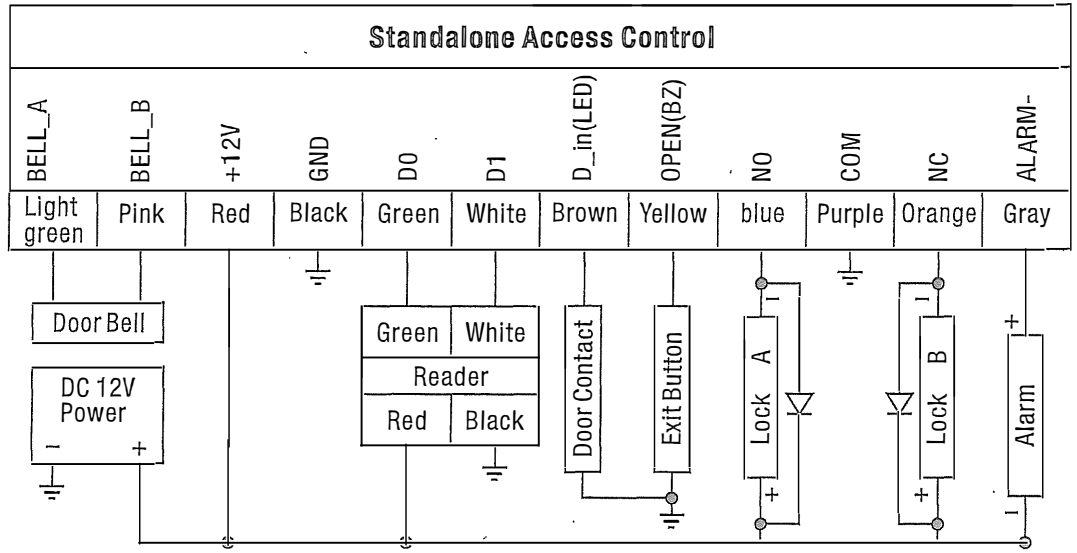

sTouch /sKey Single door(DC power supply)

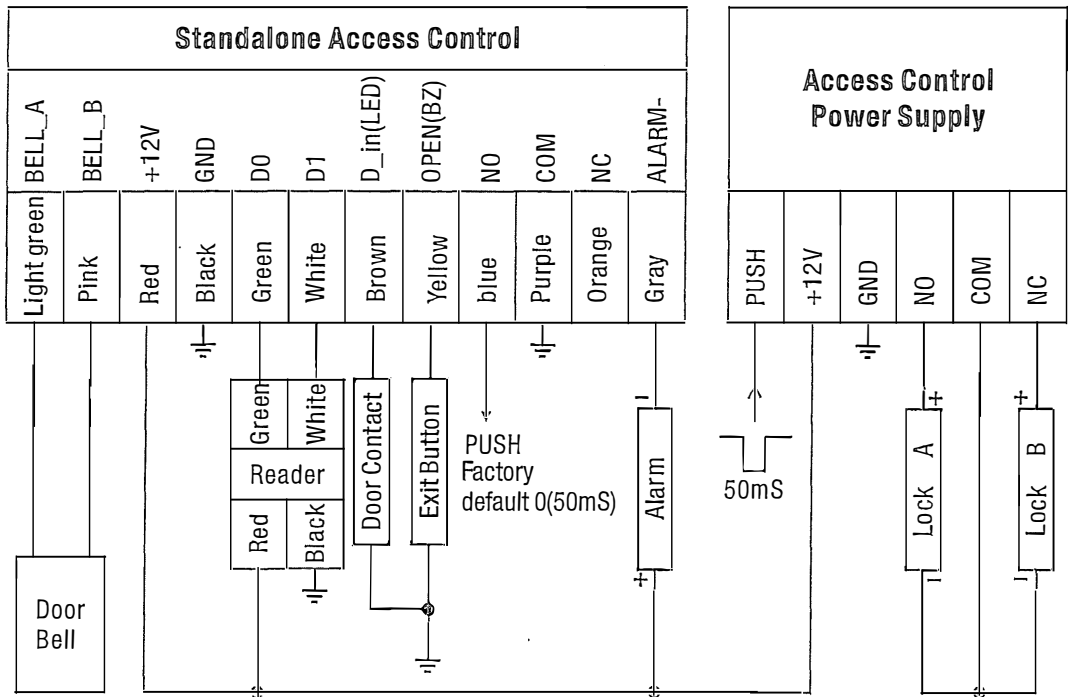

sTouch/sKey Single door(Special access control power supply)

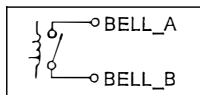

Principle of Door Bell Connector

Each press of door bell button, contact of relay in BELL_A and BELL_B will close contact for 200ms then release.

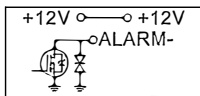

Principle of Alarm Connector

The field-effect tube will be conducted when alarm is activated; It will be not conducted when alarm is removed

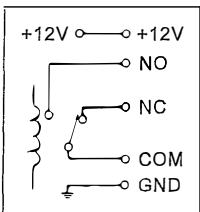

Principle of Electronic Lock

The relay will close contact to unlock the lock and will release after unlocking
COM: common, relay contact

NC: normal close, normally keep closed to COM

NO: normal open, normally keep opened to COM

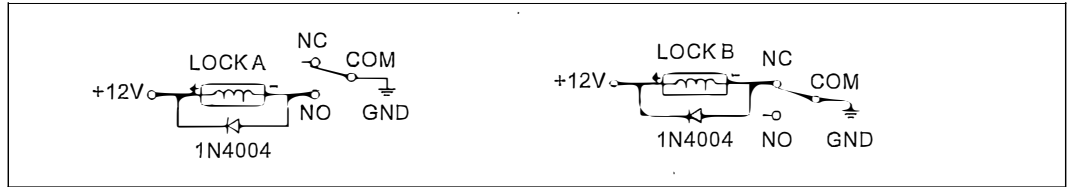

Wiring of electronic lock

Connect COM and GND, connect two ends of electronic lock with +12V and NO (or NC), complete the circuit.

Type A electronic lock: Fail Secure lock (Unlock when power on), such as Electronic Controlling Lock, smart lock, etc.

Type B electronic lock: Fail Safe lock (Unlock when power off), such as Electromagnetic Lock, Electronic Bolt Lock, etc.

1N4004 Diode: prevent high voltage to two ends of the electronic lock while the contact of relay disconnect. Without diode, there will be high voltage pulse interference to circuits and the life time of the relay will be greatly reduced.

3. Manager Cards Operation

3.1 Add user card(s) (In dual door mode, users can be only added to zone 1)

Read manager add card | Read Usercard | Read manager add card

Cards can be added continuously.

3.2 Delete user card(s)

Read manager delete card | Read User card | Read manager delete card

Cards can be deleted continuously.

4. User Operation

4.1 To unlock the lock by one card: Read valid card once, the lock will be unlocked.

4.2 To unlock the lock for card and PIN users

Read valid card once | Input 4-6 digits PIN | #, the lock will be unlocked.

4.3 To unlock the lock for card or PIN users

Read valid card | Or | Input 4-6 digits PIN | #, the lock will be unlocked

4.4 To unlock the lock for multi-cards: Read 2-10 pcs valid cards (time interval can not exceed 5s), the lock will be unlocked.

Precondition: Set the door entry by card only, and set "2-10" for opening the door by multi cards

4.5 Toggle Mode

In normal mode, Every time a valid card/tag read or PIN input, the relay will operate, for the pre-set replay pulse time.

Every time a valid card/tag read or PIN input in Toggle mode, the relay changes state, which will not turn back until read card/tag or input PIN again.

4.6 To change the PIN of a PIN user

* | Read card | Input old PIN | # | Input new PIN | # | Input new PIN | #

Or

* | User ID number | Input old PIN | # | Input new PIN | # | Input new PIN | #

Remark:

For users without card, must get ID number and initial PIN from the master. For Zone 1, the first digit of PIN must be "1", for Zone 2, the first digit of PIN must be "2" For the card users with PIN "1234", must use Reading card to change the PIN for the first time.

4.7 Door Bell

Press the door bell button on the access control unit, the buzzer will sound ring back tone, at the same time, the I box's built-in door bell or the outer door bell will ring.

Remark: When the work mode is set in Auto Mode (Factory Default Mode), there will be no ring back tone without the I Box.

5. Alarm

5.1 Anti Tamper Alarm

When the access control unit is disassembled illegally, the access control unit's buzzer and the external alarm will operate.

5.2 Door Status Switch

When connect with door status switch, if the door is opened illegal, the access control unit's buzzer and the external alarm will operate.

5.3 Anti-duress alarm

When read zone 1 duress card / input 8digits duress PIN OR zone 2 duress card / input 8digits duress PIN, then press #, the corresponding lock will open, at the same time, the external alarm will operate, but the access control unit's buzzer will not operate.

5.4 To remove the alarm

Read valid card or input master code can remove the alarm. If there is no operation, the alarm will remove automatically after 1 minute.

6. Keypad lockout or alarm

To prevent consecutive enter of an invalid master code, user password, or anti-duress or invalid card, this function will be activated after 10 times consecutive errors input. There are 3 mode available: No keypad lockout or alarm, keypad locked for 10 minutes, alarm for 1-3 minutes.

7. To Reset to Factory Default

Keypad access control(sKey-w, sKey-s), power off, keep pressing [*] and power on, the logo will turn in orange after 1 second, release it until hearing two shot beep, then hearing a long beep, enter normal mode, reset to factory default setting is successfully.

Touch panel access control(sTouch-w, sTouch-s), power off, power on, the logo will turn in orange after 1 second, press [*] within 1 second, release it until hearing two shot beep, then hearing a long beep, enter normal mode, reset to factory default setting is successfully.

Remark: Reset to factory default, the users' information is still retained.

8. Sound and Light Indication

Operation Status	Logo Color	Buzzer
Standby	White	
Press Key		Short Ring
Read Card	Green	Long Ring
Unlock the lock	Green	Long Ring
Operation Successful	Green	Long Ring
Operation Failed		3 Short Ring
PIN Inputting	Slow Flash Red	
Card & PIN Reading	Slow Flash Red	
Multi Card Reading	Slow Flash Red	
1 st Menu	Slow Flash Red	
2 nd Menu	Slow Flash Orange	

Under Setting	Orange	
Manager Card Reading	Orange	2 Short Ring
Manager Card Exit	White	Long Ring
Alarm	Quick Shine in Red	Alarm
Ring-back Tone		Ding-Dong

9. Master Setting

Logo LED Light indication		Remarks	Functions
White logo	Red logo LED flash	Factory default : 888888	To enter the programming mode
*	6-8 digits Master code #		

Enter Master Operation Mode. It will return to normal mode if there is no right Master PIN input in 5 seconds. After input of right master PIN, it will also return to normal mode if there is no valid operation in 30 seconds. Press “#” to confirm the input number, return to previous menu by press “*”, the logo light will indicate the operation mode.

Note that to undertake the following programming, the master user must be logged in

9.1 Basic Operation :

Basic Operation			
Red Flash	Orange	Functions	Remarks
0	6~8 digits new master code # Repeat 6~8 digits new master code #	Factory default : 888888	Change the master code
1	Read card	1. The user ID number is any number among 1-2000. 2. Card number must be 8 or 10 digits, if the card number is less than 8 or 10 digits, input 0 before the card number 3. User can be added continuously without exiting programming mode	Rotate Operation [®] To add card users [®]
	1-2000(ID), #, read card		
	8 or 10 digits card number [®] #		
	1~2000(User ID number), #, 8 or 10 digits card number #	To add PIN users	
2	Read card	Delete one card	Rotate Operation
	8 or 10 digits card number , #	Delete one user	
	1~2000(User ID number), #		
2	0000, # (Note: This is a dangerous option, so use with care)	Delete All users	
3	0, #	Entry is by Card only	To set open way
	1, #	Entry is by Card and PIN together	
	2, #	Entry is by either card or PIN (Factory default setting)	
4	0, #	To set door relay time 50mS	Factory default setting: 50mS
	1-99, #	To set door relay time 1-99S	

Note:

- ① 8 digits card number, such as: 118, 32319, some cards has no mark of the first 3 digits 118, remains 32319, it requires to add card by read card, adding cards by input card number is not acceptable; 10 digits card number, such as 0007765567, some cards has no mark of the first 3 digits 000,remains 7765567, requires to input 10 digits 0007765567 by add 000 before 7765567.
- ② A PIN 1234 is added for a card, it can not be used to unlock the lock, can be used to change PIN.
- ③ After one card is added, you can continue to add other cards or PIN without exiting the mode 1.

9.2 Advanced operation:

Advanced Application				
Red Flash	Orange Flash	Orange	Functions	Remarks

6	1	Read card	Set add card	To add card user
	2	Read card	Set delete card	To delete card user
	3	Read card	To set duress users	To set duress user
	4	8 digits duress PIN,#	To set duress PIN	To set duress PIN
	5	0, #	Automatic mode (Factory default)	Relay setting
		1, #	Set Zone 1 as Auto-lock switch ①	
	6	1-10, #	Factory default setting :1	To set open door by multi cards②
	7	User ID number # card number # card quantity #	The card number must be consecutive Card quantity is between 1-2000	To add a series cards users. ③
	9	1	Administrator open door 1	Exit automatic④
System Setting				
7	0	1-15, #	Factory default setting: 0	To set facility code
	1	0, #	Wiegand reader mode	To set working mode
		1, #	Standalone for single door (Factory default)	
		5, #	Anti-passback for single door	
	2	26-37, #	(Factory default setting: 26)	To set Wiegand format
	3	0, #	4-6 digis key press sends card number	To set keypad transmission format
		1, #	Each key press sends 4 bit output data (Factory default)	
		2, #	Each key press sends 8 bit output data	
	4	0, #	Close Alarm⑤	To set Alarm
		1-3, #	Alarm time is 0-3 minutes for option (Factory default 1 minute)	
	Opeional Setting			
8	1	0, #	Indicator light OFF⑥	To set logo LED light
		1, #	Indicator light ON (Factory default)	
	2	0, #	Disable buzzer ⑦	
		1, #	Enable buzzer (Factory default)	
	3	0, #	Disable keypad backlight	
		1, #	Enable keypad backlight (Factory default)	
		2, #	Auto mode⑧	
	4	0, #	Disable anti tamper alarm (Factory default)	
		1, #	Enable anti tamper alarm	
	5	0, #	No keypad lockout or alarm (Factory default)	
		1, #	In 10 minutes, if there's 10 times⑨invalid card or wrong password, the device will lock on for 10 minutes.	
		2, #	In 10 minutes, if there's 10 times invalid card or wrong password, the device will alarm.	

Remark:

- ① Every time a valid card/tag read or PIN input in in Toggle mode, the relay changes state, which will not turn back until read card/tag or input PIN again.
- ② The door will open only when read the valid card quantity up to the quantity set. It is only for Card Only mode.
- ③ The card number must be consecutive, Card quantity is between 1-2000.
- ④ After unlocking, enter the normal working state.
- ⑤ After closed the alarm, anti tamper, anti-duress and door magnetic alarm are invalid.
- ⑥ Refers to static state, normal indication according to operation.
- ⑦ Enter the administrator password correctly, the buzzer alarm in the normal phonation.
- ⑧ Each key press or read card, keypad backlight will light 30S delay after the close, in close state , the first key is just to start the keyboard light, no any function.
- ⑨ 10 times consecutive errors including: enter an invalid master code, user password, or anti-duress or invalid card.

10. Various Working Modes Application

The device has 3 working modes:

1. Wiegand Reader
2. Standalone for single door (Factory default setting)
3. Anti-pass back for single door

Through Wiegand data lines, can make the device and external card reader are connected together, to realize of various functions.

Card number and PIN etc information will store in the device.

The external reader only read card or as a device for input PIN, you can connect with a numbers of readers, but function all same.

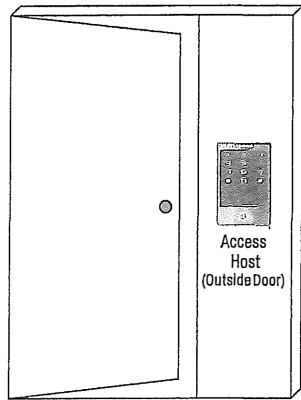

Standalone for single door

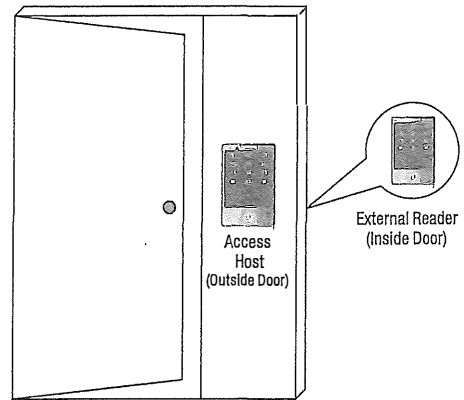

Anti-pass back for single door

10.1 Wiegand Reader Mode

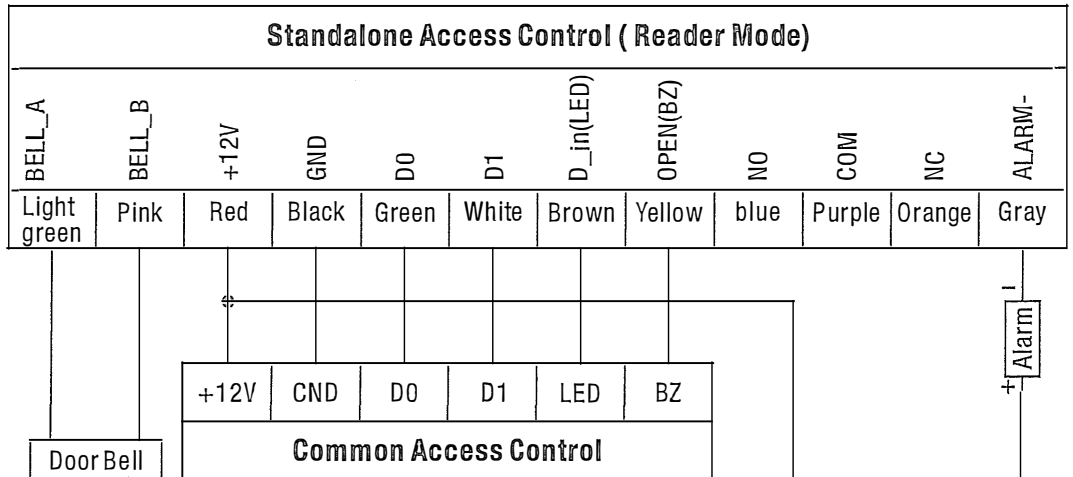

sTouch/sKey Reader Wiring Diagram

In this mode, the access host works as reader, it can be done below settings.

Adminrator Setting				
White	Red flash	Functions	Remarks	
*	6-8 digits Master code #	Enter programming mode	Factory default : 888888	
Reader Setting				
Red Flash	Orange Flash	Orange	Functions	Remarks
0		6~8 digits new master code # Repeat 6~8 digits new master code #	Factory default : 888888	Change the master code

7	0	0-15, #	Factory default setting: 0	To set facility code
	2	26-37, #	Factory default setting:26	To set Wiegand format
	3	0, #	4-6 digis key press sends card number	To set keypad transmission format
		1, #	Each key press sends 4 bit output data (Factory default setting)	
		2, #	Each key press sends 8 bit output data	
	4	0, #	Close Alarm	To set Alarm
		1-3, #	Alam time is 0-3 minutes for option	
	5	0, #	No door bell function	To set door bell function
		1, #	Built-in door bell- ON (Factory default setting)	
		2, #	External door bell-ON	
3, #		Built-in & external door bell - ON		
8	1	0, #	Disable	To set logo LED light
		1, #	Enable(Factory default setting)	
	2	0, #	OFF-The device will be in silence except enter the programming mode	To set keypad tone ON or OFF
		1, #	ON-The device will give the voice when press the keys (Factory default setting)	
	3	0, #	Disable keypad backlight	To set keypad backlight
		1, #	Enable keypad backlight (Factory default setting)	
		2, #	Automatic mode Normally it is off(sleeping mode) but wake up with human approach	To set keypad backlight
	4	0, #	Disable anti tamper alarm (Factory default setting)	To set anti tamper alarm
		1, #	Enable anti tamper alarm	

When LED level is low, logo light will turn into Green, after 30 seconds or LED level rising, Logo light will back to normal.

When BZ level is low, the Buzzer will beep, after 30 seconds or BZ level rising, the Buzzer will back to normal.

When the access host worked as reader, both card number and keypad transmits in Wiegand format, the output data are shown by the Low Level of D0 & D1 cable:

D0: Low level means 0, green cable

D1: Low Level means 1, white cable

The Pulse Width of Low level is 40uS, Bit period is 2mS.

The digit of Car number can be set to 26~27Bit, should be matched with the controller. (Factory default is 26Bit)
Wiegand 26 card reader, HID card can output Wiegand 26~37 automatically, other cards are output Wiegand 26 compulsively.

Wiegand 27~37 card reader, all cards are forced output Wiegand 27~37.

Keypad transmission can be set in the following 3 modes

Model 0: The Reader will transmit the PIN data when it receives the last key (#) press after PIN code
Format: Decimal card number with 10-digit , Facility Code(1st ~ 4th digit)+ PIN Code (5th ~ 10th digit)
(Facility code is any digits between 0~15, PIN code is 4~6 digits)

Example: Facility code:15

PIN code: 2999

Press 2999 #, then output format will be: 0015002999

PIN code: 999999

Press 999999#, then output format will be 0015999999

Model1: 4-Bit

The output data is provided in following format after every key is pressed:

1 (0001) , 2 (0010) , 3 (0011)
4 (0100) , 5 (0101) , 6 (0110)
7 (0111) , 8 (1000) , 9 (1001)
* (1010) , 0 (0000) , # (1011)

Model 2: 8-Bit

The output data is transmitted in following format after every key is pressed:

1 (11100001) , 2 (11010010) , 3 (11000011)
4 (10110100) , 5 (10100101) , 6 (10010110)
7 (10000111) , 8 (01111000) , 9 (01101001)
* (01011010) , 0 (11110000) , # (01001011)

10.2 Standalone for Single door

In this mode, the access host uses can open the door by valid card or PIN, it supports connecting external card reader for exiting door.

When input duress PIN/Card, the door will open, at the same time, the external alarm operates

10.3 Anti-passback for Single Door

- > In this mode, access host install outside is for entering door, external reader inside for exiting door, they build up a single door anti-passback system, access host is the anti-passback master unit.
- > Read valid card or input PIN on access host, door will open; read valid card or input PIN on external reader, door will open.
- > When input duress PIN/Card, the door will open, at the same time, the external alarm operates
- > When input duress PIN/Card on external reader, the door will open, at the same time, the external alarm operates.
- > Open type forced Card Only, the user PIN is invalid.
- > The users can only enter door when read valid card on access host, and exit from the inside external reader, If without the entering record from access host, the users can not exit from the inside reader, also the users can't enter in twice without the first exit record.

11. Simple Troubleshooting

Fault Phenomenon	Fault Cause	Reason & Solution
Reading distance is too close	1. Card problem 2. Switch power supply interferences card reading	1. Please use original made card 2. Wiring power supply and access host shell to ground wire
Set user PIN failed	1. Wrong way of PIN setting 2. Setting PIN under card reading mode	1. In mode of two Doors 1, the 1st digit of PIN must be 1. Two doors 2, the 1st digit of PIN must be 2. 2. User PIN cannot be 1234 3. User PIN only can be 4~6 digits
Can't open door after inputting user's PIN	Use 1234 as user's PIN	1234 is the initial value, can't be used to open doors, unless after resetting them to other 4~6 digits
Alarm under normal situation	Light leaking when install access host	Leaning on wall closely when install access host
No reaction when reading card	not on standby status	Exit by pressing <input type="checkbox"/> until logo light turns to white
Keypad light off	Set keypad light mode improperly	1. Set the keypad light to always On or automatic mode 2. Under automatic mode, keypad light will on when people approaching
Cannot enter Administrator setting mode	Forget master code	Reset to Factory Default, default master code is 888888, need to reset conditions and specifications, but users' information is still retained

For other issues beyond above, welcome to contact our technicians for more details.