

Instructions for Installation of Central Door Locking System

PARTS FOR 2-DOOR SYSTEM

1 pc	Control module
2 pcs	5-wire actuator/door lock
1 pc	Wiring harness
2 pcs	Connecting rods
2 pcs	Adjustable steel mounting straps
1 pack	hardware parts, each pack includes:
	1 pc Control module screw (5x16mm)
	2 pcs Connecting rod clamp
	4 pcs Clamp fitting screws (4x6mm)
	4 pcs Folded metal speed nuts
	8 pcs Philips-head sheet metal screws bolts (4x25.4mm)

PARTS FOR 4-DOOR SYSTEM

1 pc	Control module
2 pcs	5-wire actuator/door lock (for front door)
2 pcs	2-wire actuator/door lock (for rear door)
1 pc	Wiring harness
4 pcs	Connecting rods
4 pcs	Adjustable steel mounting straps
1 pack	hardware parts, each pack includes :
	1 pc Control module screw (5x16mm)
	4 pcs Connecting rod clamp
	8 pcs Clamp fitting screws (4x6mm)
	8 pcs Folded metal speed nuts
	16 pcs Philips-head sheet metal screws bolts (4x25.4mm)

ACTUATOR/DOOR LOCK & CONTROL MODULE INSTALLATION

1. Carefully remove door panel.
2. Since adjustable steel mounting strap is optional at this step, you can either attach strap to door structure and mount actuator/door lock to strap, or attach actuator/door lock onto door structure. Both to insure a suitable position is selected that will not hinder the window mechanism and is close enough to operate the existing lock assembly.

AANR

3. Slide connector rod onto the end hole of actuator/door lock. Attach connector rod clamp to connector rod.
4. Set door lock in the unlock position, then tighten connector rod clamp with clamp fitting screw.
5. Pull connector rod until actuator is fully extended, then tighten connector rod clamp to existing door rod.
6. Install control module close to fuse-box which is usually under dashboard. Never mount control module in engine compartment.

WIRING INSTALLATION

1. Run wiring harness along the bottom of door cavity. Be sure that no sharp edge from door structure will puncture wires. Use rubber sleeves to protect wires if required.
2. Connect 5-wire actuator/door lock to the wiring harness in accordance with same color.
3. Repeat step 2 for all other actuators/door locks installation.
4. Connect separate black wire from wiring harness to ground.
5. Connect separate red wire from wiring harness to the battery (+) or to a constant source of 12/24 voltage.
6. Connect wiring harness to control module

TESTING

1. Press front door lock down to locked position. When pressed down all actuators/door lock connected to the system will pull to locked position. When front door lock is brought to unlocked position, all actuators connected to the system will push to unlocked position.
2. Control locking system of all doors is applied to front door actuators/door lock ONLY.
3. In some car mechanism, reversed actuator wires is required for normal function. For 2-wire actuator, switch green(blue)- green(blue) and blue(red)- blue(red) to green(blue)-blue(red) and blue(red)-green(blue). Repeat this step for white(purple) /brown(brown) wires for 5-wire actuator if required.
4. Make sure system operates correctly before reassemble door panel.

DRAWING 1

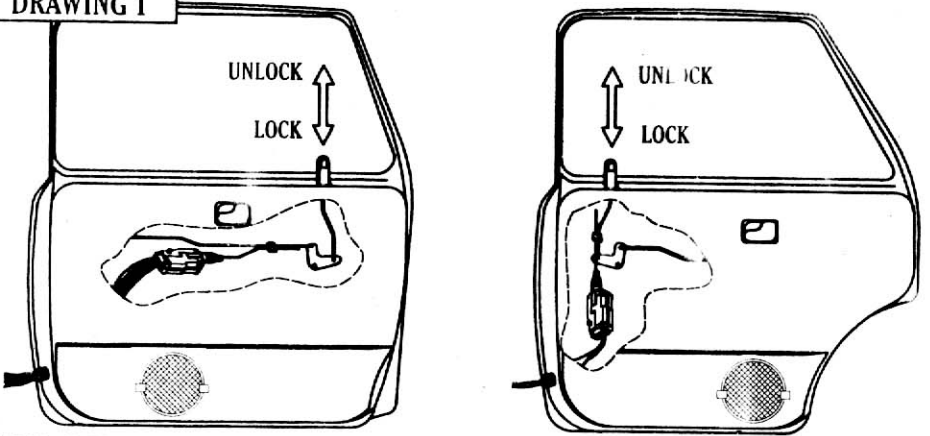

RUBBER SLEEVE

RUBBER SLEEVE

DRAWING 2

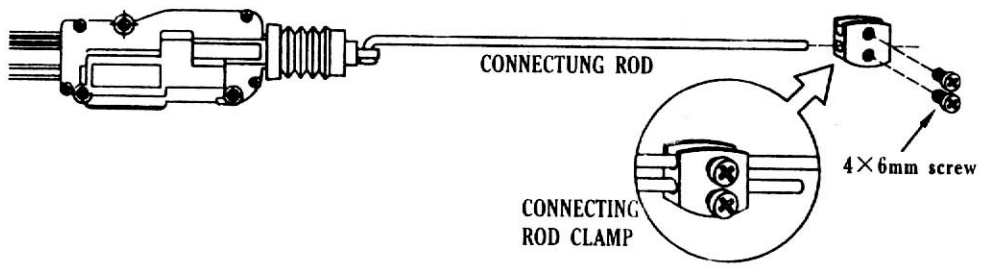

CONNECTUNG ROD

CONNECTING ROD CLAMP

4x6mm screw

DRAWING 3

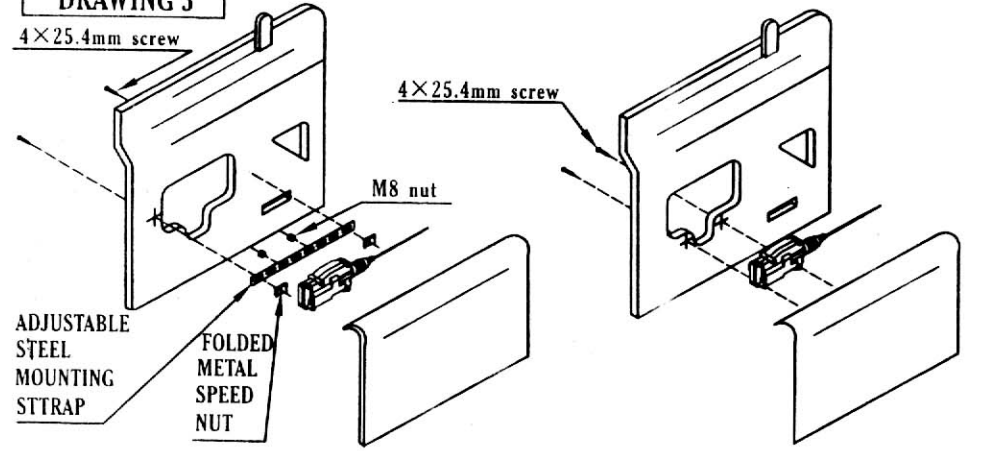

4x25.4mm screw

4x25.4mm screw

M8 nut

ADJUSTABLE STEEL MOUNTING STRAP

FOLDED METAL SPEED NUT

WIRING DIAGRAM

