

Grandstream Networks, Inc.

**GSC35x6 (V2) - User Manual**



# WELCOME



The GSC3516 is a SIP intercom speaker and microphone that allows offices, schools, hospitals, apartments, and more to build powerful voice intercom solutions that expand security and communication. This robust SIP intercom device offers 2-way voice functionality with both a high fidelity 15W HD speaker and 3 directional microphones with Multichannel Microphone Array Design (MMAD) and 1 omnidirectional auxiliary microphone that offers a 4.2-meter pickup distance. The GSC3516 supports a wide range of peripherals including Bluetooth devices, a built-in whitelist, and blacklists to block unwanted calls easily, integrated dual-band Wi-Fi, and advanced acoustic echo cancellation. By pairing the GSC3516 with other Grandstream devices, including desktop and cordless IP phones as well as the GDS series of Facility Access products, users can easily sculpt a state-of-the-art security and voice intercom solution. Thanks to its modern industrial design, a cleanable exterior surface, and rich features, the GSC3516 is the ideal intercom speaker/microphone for any setting.

The GSC3506 and GSC3506 V2 are a 1-way public address SIP speaker that allows offices, schools, hospitals, apartments, and more to build powerful public address announcement solutions that expand security and communication. This robust SIP speaker offers crystal clear HD audio functionality with a high-fidelity 30-Watt HD speaker. The GSC3506 and GSC3506 V2 support built-in whitelists, blacklists, and greylists to easily block unwanted calls, SIP and multicast paging, group paging, and Push-to-Talk. users can easily sculpt a state-of-the-art security and PA announcement solution. Thanks to their modern industrial design and rich features, the GSC3506 and GSC3506 V2 are the ideal SIP speakers for any setting.

## PRODUCT OVERVIEW

### Feature Highlights

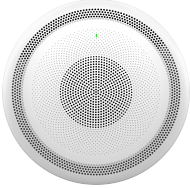
The following table contains the major features of the GSC35x6 (V2):

 <p><b>GSC3516</b></p>	<ul style="list-style-type: none"><li>● Up to 16 SIP accounts.</li><li>● Ethernet RJ45 10/100Mbps, PoE/PoE+, Integrated Bluetooth, Wi-Fi.</li><li>● 2-way voice functionality with both a high-fidelity 15W HD speaker and 3 directional microphones with Multichannel Microphone Array Design (MMAD) and 1 omnidirectional auxiliary microphone that offer a 4.2 meter pickup distance</li></ul>
 <p><b>GSC3506</b></p>	<ul style="list-style-type: none"><li>● Up to 16 SIP accounts.</li><li>● Ethernet RJ45 10/100Mbps, PoE/PoE+</li><li>● 1-way public address SIP speaker with crystal clear HD audio functionality with a high-fidelity 30-Watt HD speaker.</li><li>● 2-Pin port enabling Alarm configuration</li><li>● USB Plug support</li></ul>
 <p><b>GSC3506 V2</b></p>	<ul style="list-style-type: none"><li>● Up to 16 SIP accounts.</li><li>● Ethernet RJ45 10/100Mbps, PoE/PoE+/PoE++</li><li>● 1-way public address SIP speaker with crystal clear HD audio functionality with a high-fidelity 30-Watt HD speaker.</li><li>● 2-Pin Switch-in input port</li><li>● 2-Pin Alarm-in input port</li><li>● Differential line out port</li><li>● USB Plug support</li></ul>

## GSC3516 Technical Specifications

The following table resumes all the technical specifications including the protocols/standards supported, voice codecs, telephony features, languages, and upgrade/provisioning settings for GSC3516.

<b>Protocols/Standards</b>	SIP RFC3261, TCP/IP/UDP, RTP/RTCP, RTCP-XR,HTTP/HTTPS, ARP, ICMP, DNS (A record, SRV, NAPTR), DHCP, PPPoE, SSH, TFTP, NTP, STUN, LLDP-MED, SIMPLE, LDAP,TR-069, 802.1x, TLS, SRTP, IPv6, OpenVPN®
<b>Network Interfaces</b>	One 10/100 Mbps port with integrated PoE/PoE+
<b>Operating System</b>	Linux
<b>Bluetooth</b>	Yes, integrated Bluetooth
<b>Wi-Fi</b>	Yes, dual-band 2.4 & 5GHz with 802.11 a/b/g/n/ac
<b>Auxiliary Port</b>	One 2-pin multi-purpose input port, Reset
<b>Voice Codecs and Capabilities</b>	G.711μ/a, G.722 (wide-band), G.726-32, iLBC, Opus, G.723, G.729A/B, in-band and out-ofband DTMF (In audio, RFC2833, SIP INFO), VAD, CNG, AEC, PLC, AJB, AGC, ANS
<b>Telephony Features</b>	SIP Paging, Multicast Paging, Group Paging, Push-to-Talk, Call-waiting with priority override, Bluetooth SCO call
<b>HD Audio</b>	Yes, HD speakerphone with support for full band audio with 48KHz voice sampling frequency
<b>Speaker</b>	15W high-fidelity HD speaker Frequency: 100Hz-20000 Hz Volume: Up to 90 dBA at 1W power at 0.5 meter
<b>Microphones</b>	3 directional microphones with beam-forming capability and up to 4.2-meter voice pickup distance and 1 omnidirectional auxiliary microphone
<b>QoS</b>	Layer 2 QoS (802.1Q, 802.1p) and Layer 3 (ToS, DiffServ, MPLS) QoS
<b>Security</b>	User and administrator level passwords, MD5 and MD5-sess based authentication, 256-bit AES encrypted configuration file, TLS, SRTP, HTTPS, 802.1x media access control,secure boot
<b>Multi-language</b>	English, German, French, Spanish, Portuguese, Russian & Chinese
<b>Upgrade/Provisioning</b>	Firmware upgrade via TFTP / HTTP / HTTPS or local HTTP upload, mass provisioning using GDMS/TR069 or AES encrypted XML configuration file
<b>Power &amp; Green Energy Efficiency</b>	Integrated PoE* 802.3af Class 3, PoE+ 802.3at Class 4
<b>Temperature and Humidity</b>	<ul style="list-style-type: none"> <li>● <b>Operation:</b> 0°C to 40°C</li> <li>● <b>Storage:</b> -10°C to 60°C</li> <li>● <b>Humidity:</b> 10% to 90% Non-condensing</li> </ul>

<b>Package Content</b>	<ul style="list-style-type: none"> <li>● GSC3516 SIP Intercom Speaker/Microphone</li> <li>● Mounting kits</li> <li>● Quick installation guide</li> </ul>
<b>Physical Specifications</b>	<ul style="list-style-type: none"> <li>● <b>Unit Dimensions:</b> 257mm (diameter) x 68.5mm (depth).</li> <li>● <b>Unit Weight:</b> 0.92kg , Box Weight: 1.75kg.</li> </ul>
<b>Compliance</b>	<ul style="list-style-type: none"> <li>● <b>FCC:</b> FCC 47 CFR Part 15 Subpart B;FCC 47 CFR Part 15 Subpart C;FCC 47 CFR Part 15 Subpart E.</li> <li>● <b>IC:</b> ICES-003;RSS-247 Issue 2;RSS-Gen Issue 5;RSS-102 Issue 5.</li> <li>● <b>CE:</b> ETSI EN 300 328;ETSI EN 301 893;ETSI EN 300 440;ETSI EN 301 489-1;ETSI EN 301 489-3;ETSI EN 301 489-17;EN 55032;EN 55035;EN IEC 61000-3-2;EN 61000-3-3;EN IEC 62311;EN IEC 62368-1.</li> <li>● <b>UKCA:</b> ETSI EN 300 328;ETSI EN 301 893;ETSI EN 300 440;ETSI EN 301 489-1;ETSI EN 301 489-3;ETSI EN 301 489-17;BS EN 55032;BS EN 55035;BS EN IEC 61000-3-2;BS EN 61000-3-3;BS EN IEC 62311;BS EN IEC 62368-1.</li> <li>● <b>RCM:</b> AS/NZS CISPR 32;AS/NZS 62368.1;AS/NZS 4268;AS/NZS 2772.2.</li> </ul>

## GSC3506 Technical Specifications

The following table resumes all the technical specifications including the protocols/standards supported, voice codecs, telephony features, languages, and upgrade/provisioning settings for GSC3506.

<b>Protocols/Standards</b>	SIP RFC3261, TCP/IP/UDP, RTP/RTCP, RTCP-XR,HTTP/HTTPS, ARP, ICMP, DNS (A record, SRV, NAPTR), DHCP, PPPoE, SSH, TFTP, NTP, STUN, LLDP-MED, SIMPLE, LDAP,TR-069, 802.1x, TLS, SRTP, IPv6, OpenVPN®
<b>Network Interfaces</b>	One 10/100 Mbps port with integrated PoE/PoE+
<b>Operating System</b>	Linux
<b>Auxiliary Port</b>	<ul style="list-style-type: none"> <li>● One 2-Pin switch-in input port.</li> <li>● One Alarm-in input port.</li> <li>● vol +/- Key,</li> <li>● Reset Button</li> <li>● Network Button</li> </ul>
<b>USB Port</b>	USB2.0, External USB used for storage purposes.
<b>Voice Codecs and Capabilities</b>	G.711μ/a, G.722 (wide-band), G.726-32, iLBC, Opus, G.723, G.729A/B, in-band and out-ofband DTMF (In audio, RFC2833, SIP INFO), VAD, CNG, PLC, AJB
<b>Telephony Features</b>	SIP Paging, Multicast Paging, Group Paging, Push-to-Talk, Call-waiting with priority override.
<b>HD Audio</b>	Yes, HD speakerphone with support for full band audio with 48KHz voice sampling frequency
<b>Speaker</b>	30W high-fidelity HD speaker Frequency: 100Hz-20000 Hz Volume: Up to 90 dBA at 1W power at 0.5 meter
<b>QoS</b>	Layer 2 QoS (802.1Q, 802.1p) and Layer 3 (ToS, DiffServ, MPLS) QoS
<b>Security</b>	User and administrator level passwords, MD5 and MD5-sess based authentication, 256-bit AES encrypted configuration file, TLS, SRTP, HTTPS, 802.1x media access control,secure boot



<b>Multi-language</b>	English, German, French, Spanish, Portuguese, Russian & Chinese
<b>Upgrade/Provisioning</b>	Firmware upgrade via TFTP / HTTP / HTTPS or local HTTP upload, mass provisioning using GDMS/TR069 or AES encrypted XML configuration file
<b>Power &amp; Green Energy Efficiency</b>	Integrated PoE* 802.3af Class 3, PoE+ 802.3at Class 4
<b>Temperature and Humidity</b>	<ul style="list-style-type: none"> <li>● <b>Operation:</b> 0°C to 40°C</li> <li>● <b>Storage:</b> -10°C to 60°C</li> <li>● <b>Humidity:</b> 10% to 90% Non-condensing</li> </ul>
<b>Package Content</b>	<ul style="list-style-type: none"> <li>● GSC3506 SIP Speaker</li> <li>● Mounting kits</li> <li>● Quick installation guide</li> </ul>
<b>Compliance</b>	<ul style="list-style-type: none"> <li>● <b>FCC:</b> FCC 47 CFR Part 15 Subpart B.</li> <li>● <b>CE:</b> EN 55032:EN 55035; EN IEC 61000-3-2: EN 61000-3-3; EN IEC 62368-1.</li> <li>● <b>IC:</b> ICES-003.</li> <li>● <b>UKCA:</b> BS EN 55032:BS EN 55035;BS EN IEC 61000-3-2;BS EN 61000-3-3;BS EN IEC 62368-1.</li> <li>● <b>RCM:</b> AS/NZS CISPR 32:AS/NZS 62368.1</li> </ul>

*GSC3506 Technical Specifications*

## GSC3506 V2 Technical Specifications

<b>Protocols/Standards</b>	SIP RFC3261, TCP/IP/UDP, RTP/RTCP, RTCP-XR,HTTP/HTTPS, ARP, ICMP, DNS (A record, SRV, NAPTR), DHCP, PPPoE, SSH, TFTP, NTP, STUN, LLDP-MED, SIMPLE, LDAP,TR-069, 802.1x, TLS, SRTP, IPv6, OpenVPN®
<b>Network Interfaces</b>	One 10/100 Mbps port with integrated PoE/PoE+/PoE++
<b>Auxiliary Port</b>	<ul style="list-style-type: none"> <li>● One 2-pin Switch-in input port</li> <li>● One 2-pin Alarm-in input port</li> <li>● One differential line out port</li> <li>● One DC24V port</li> <li>● One network port</li> <li>● Vol +/- Key</li> <li>● Reset Button</li> </ul>
<b>USB Port</b>	USB2.0, External USB Storage
<b>Voice Codecs and Capabilities</b>	G.711μ/a, G.722 (wide-band), G.726-32, iLBC, Opus, G.723, G.729A/B, in-band and out-ofband DTMF (In audio, RFC2833, SIP INFO), VAD, CNG, PLC, AJB, AGC, ANS
<b>Telephony Features</b>	SIP Paging, Multicast Paging,Group Paging, Push-to-Talk, call-waiting with priority override
<b>HD Audio</b>	Yes, HD speaker with support for full-band audio
<b>Speaker</b>	30W high-fidelity HD speaker(coaxial) Frequency: 110Hz-20000 Hz Sensitivity: Up to 95 dBA at 1W power at 1 meter

<b>QoS</b>	Layer 2 QoS (802.1Q, 802.1p) and Layer 3 (ToS, DiffServ, MPLS) QoS
<b>Security</b>	User and administrator level passwords, MD5 and MD5-session based authentication, 256-bit AES encrypted configuration file, TLS, SRTP, HTTPS, 802.1x media access control, secure boot
<b>Multi-language</b>	English, German, French, Spanish, Portuguese, Russian & Chinese
<b>Upgrade/Provisioning</b>	Firmware upgrade via TFTP / HTTP / HTTPS or local HTTP upload, mass provisioning using GDMS/TR069 or AES encrypted XML configuration file
<b>Power &amp; Green Energy Efficiency</b>	Integrated PoE* 802.3af Class 3, PoE+ 802.3at Class 4, PoE++ 802.3bt Class 6
<b>Temperature and Humidity</b>	<ul style="list-style-type: none"> <li>● <b>Operation:</b> 0°C to 45°C</li> <li>● <b>Storage:</b> -10°C to 60°C</li> <li>● <b>Humidity:</b> 10% to 90% Non-condensing</li> </ul>
<b>Package Content</b>	<ul style="list-style-type: none"> <li>● GSC3506 V2 SIP Speaker</li> <li>● Mounting hole cut-out template</li> <li>● Ceiling mount kit (optional)</li> <li>● Quick installation guide</li> </ul>
<b>Physical</b>	Unit Dimensions: 257.5mm (diameter) x 118mm (depth) Unit Weight: 2.09kg, Box Weight: 2.755kg
<b>Compliance</b>	<ul style="list-style-type: none"> <li>● <b>FCC:</b> FCC 47 CFR Part 15 Subpart B</li> <li>● <b>CE:</b> EN 55032:EN 55035; EN IEC 61000-3-2: EN 61000-3-3; EN IEC 62368-1</li> <li>● <b>IC:</b> ICES-003</li> <li>● <b>UKCA:</b> BS EN 55032; BS EN 55035; BS EN IEC 61000-3-2; BS EN 61000-3-3; BS EN IEC 62368-1</li> <li>● <b>RCM:</b> AS/NZS CISPR 32:AS/NZS 62368.1</li> </ul>

*GSC3506 V2 Technical Specifications*

## GETTING STARTED

This chapter provides basic installation instructions including the list of the packaging contents and also information for obtaining the best performance with the GSC3516/GSC3506/GSC3506 V2.

### Equipment Packaging

#### GSC3516

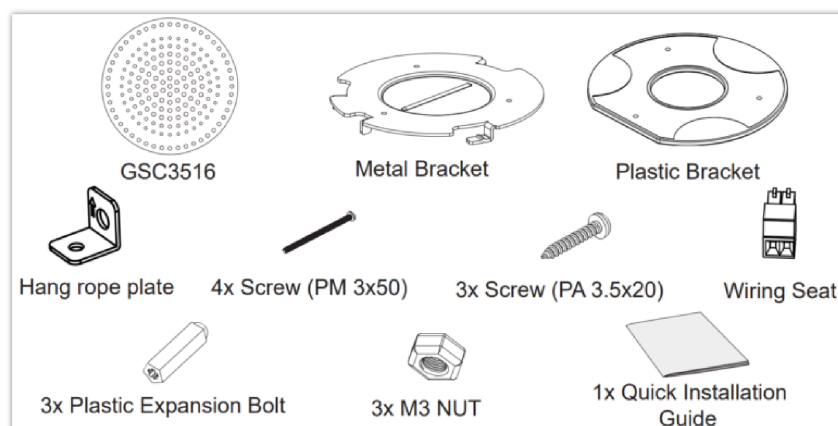

1x GSC3516 Main Case.
1x Metal Bracket
1x Plastic Bracket
Hang rope plate
4x Screw (PM 3x50)
3x Screw (PA 3.5x20)
Wiring Seat
3x Plastic Expansion Bolt
3x M3 NUT
1x Quick Installation Guide

*Equipment Packaging*

**Note**

Check the package before installation. If you find anything missing, contact your system administrator.

**GSC3516 Ports**

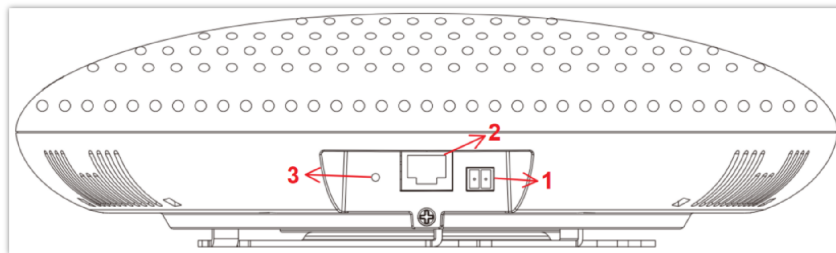

GSC3516 Ports

1	<b>2-PIN Port</b>	2-PIN Multi-Purpose Input Port.
2	<b>NET/PoE</b>	Ethernet RJ45 port (10/100Mbps) supporting PoE/PoE+.
3	<b>RESET</b>	Factory reset pinhole. Press for 10 seconds to reset factory default settings.

*Ports Description*

**GSC3506**

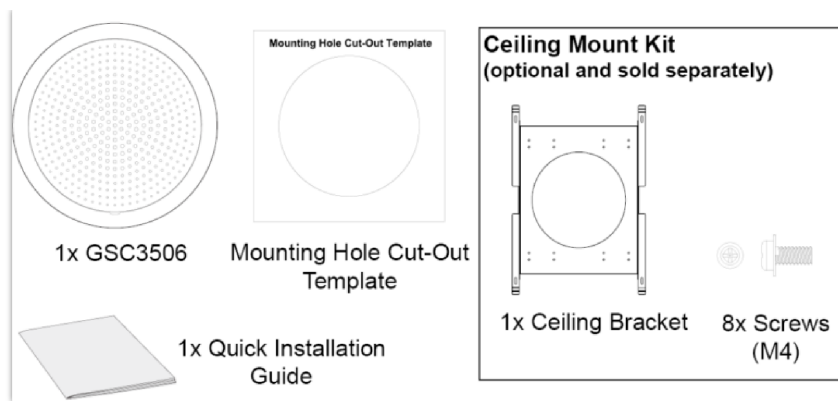

GSC3506 Package Content

1x GSC3506
1x Mounting Hole Cut-Out Template
1x Quick Installation Guide

### GSC3506 Ports and buttons

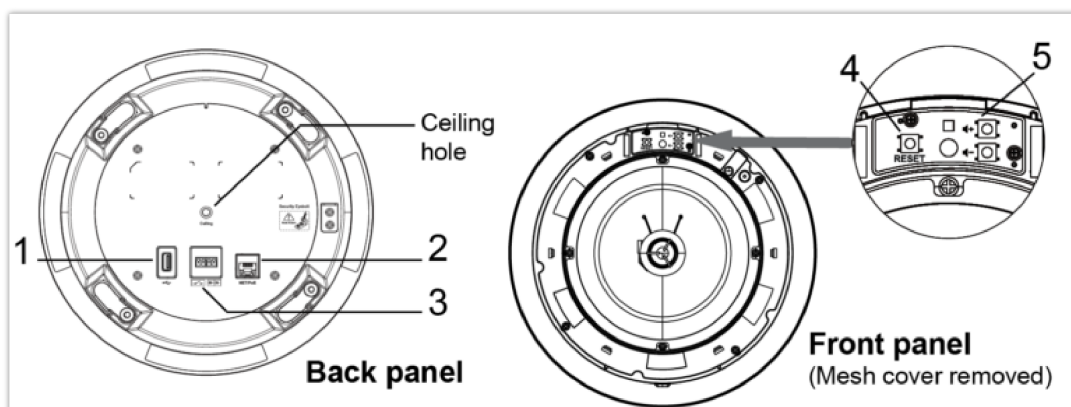

GSC3506 Ports and Buttons

1	<b>USB Port</b>	USB2.0, External USB Storage.
2	<b>NET/PoE</b>	Ethernet RJ45 port (10/100Mbps) supporting PoE/PoE+.
3	<b>2-PIN Port</b>	2-pin switch-in input port Alarm-in input port (Access voltage 5V to 12V).
4	<b>RESET</b>	Factory reset button. Press for 10 seconds to reset factory default settings.
5	<b>Volume</b>	Sound Volume buttons.

### GSC3506 V2

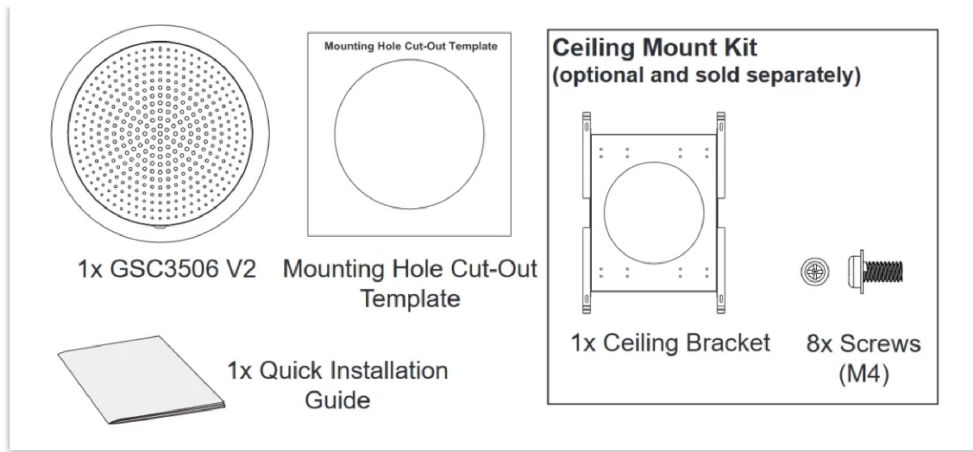

GSC3506 V2 Package Content

1x GSC3506 V2
1x Mounting Hole Cut-Out Template
1x Quick Installation Guide
1x Ceiling Bracket <i>(optional and sold separately)</i>
8x (M4) Screws <i>(optional and sold separately)</i>

### GSC3506 V2 Ports and buttons

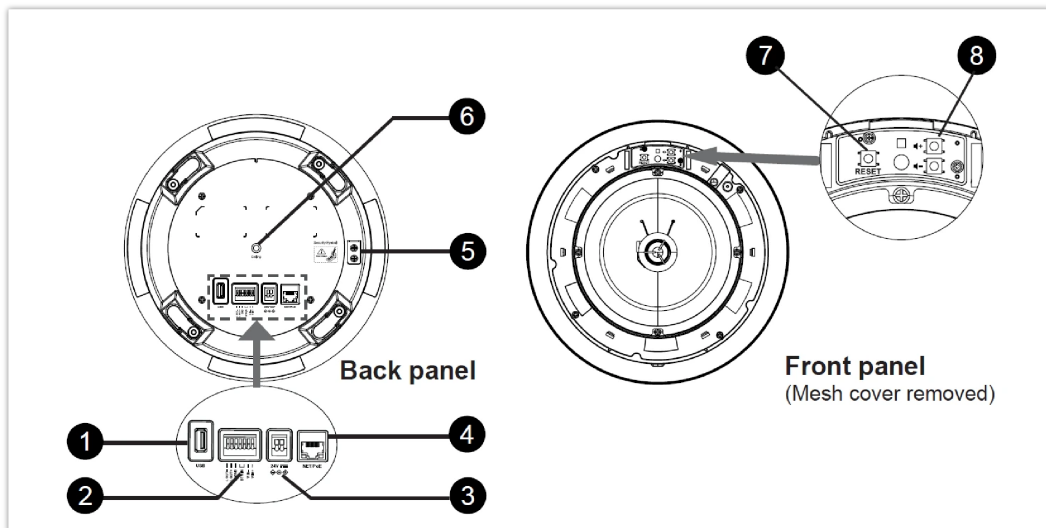

GSC3506 V2 Ports and Buttons

	Label	Description
1	USB Port	USB2.0, External USB Storage
2	Auxiliary Ports	2-pin Switch-in input port /2-pin Alarm-in input port /2-pin differential line out port /1-pin GND port

3	DC24V port	One DC24V port
4	NET/PoE	Ethernet RJ45 port (10/100Mbps) supporting PoE/PoE+/PoE++.
5	Security Eyebolt	Security Eyebolt (Must Attach)
6	Ceiling hole	Ceiling hole position
7	Reset	Factory reset button. Press for 10 seconds to reset factory default settings
8	Volume	Sound Volume buttons

#### Note

Check the package before installation. If you find anything missing, contact your system administrator.

## LED Indicators

The GSC35x6 (V2) contains 4 types of colored LEDs (Red, Green, White and Blue light) that are used in some specific situations and operations. Please, refer to the following table describing each one of the LED Indicators' statuses:

Color	LED Indicator Status	Description
Red Light	Fast Flashing (every 1s)	Rebooting/factory resetting
	Slow Flashing (On 1s, Off 2s)	Unhandled event: (Included Missed call(s), new voice mails, new SIP messages). <i>Note: In case it's connected via Bluetooth, Missed Call/Voicemail Red LED will not light and will remain flashing in blue.</i>
	Solid Red	The contacts/storage space is full
Green Light	Fast Flashing (every 1s)	Incoming calls / outgoing call (only for GSC3516)
	Slow Flashing (On 1s, Off 2s)	Call on hold.
	Solid Green	During the call.
White Light	Fast Flashing (every 1s)	Upgrading the firmware.
Blue Light	Fast Flashing (every 1s)	Bluetooth pairing. ( only for GSC3516)

#### LED Indicators

## Hardware Installation

### GSC3516 Hardware installation

GSC3516 can be mounted on the wall or ceiling. Please refer to the following steps for the appropriate installation :

## Wall Mount

1. Locate the equipment holder in the desired position with the arrow up. Drill three holes on the wall referring to the positions of holes on the metal bracket.
2. Fix the metal bracket on the wall with expansion screws.
3. Align the position line on the device's back cover with the positioning slot.
4. Rotate the device clockwise until it is locked in the right position.

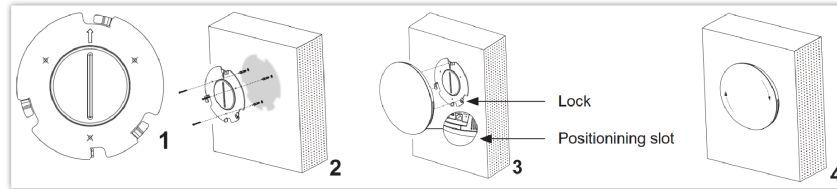

Wall Mount

## Ceiling Mount

1. Put the ceiling mounting (metal bracket) in the ceiling's center and mark the position of the three screw holes.
2. Drill a round hole with a diameter of 18mm for the Ethernet cable. The distance between its center and the highlighted hole on the plastic bracket should be 35mm.
3. Fix the plastic and metal brackets on the ceiling with flat-head screws and locknuts. Then place an Ethernet cable pass through the 18mm-round hole.
4. Align the position line on the device's back cover with the positioning slot.
5. Rotate the device clockwise until it is locked in the right position.

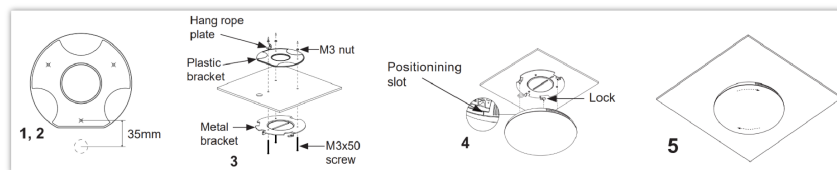

Ceiling Mount

## Anti-theft Installation

After the device is assembled with the metal bracket support on the wall or ceiling, use the anti-detachable screw (M3 x 50) in order to prevent theft.

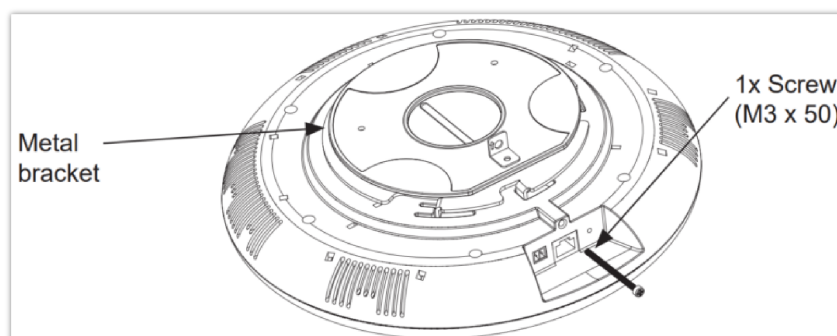

Anti-theft Installation

## GSC3506 Hardware installation

GSC3506 can be mounted on the ceiling or the Boom. Please refer to the following steps for the appropriate installation.

### Ceiling Mount

1. Drill a round hole with a diameter of 230mm or use the Mounting Hole Cut-Out Template.

2. To ensure safety, install first the anti-fall ropes, then plug in the Ethernet and 2-pin cables.
3. Open the front cover with a flat-head screwdriver.
4. Align the device with the hole and push it up slowly with two hands.
5. Use a screwdriver and gently rotate clockwise the screws marked as (1), (2), (3), and (4) in the step 5 illustration.
6. Align the notch on the front cover with the notch on the device, and press the whole front cover to ensure that each buckle is fastened.

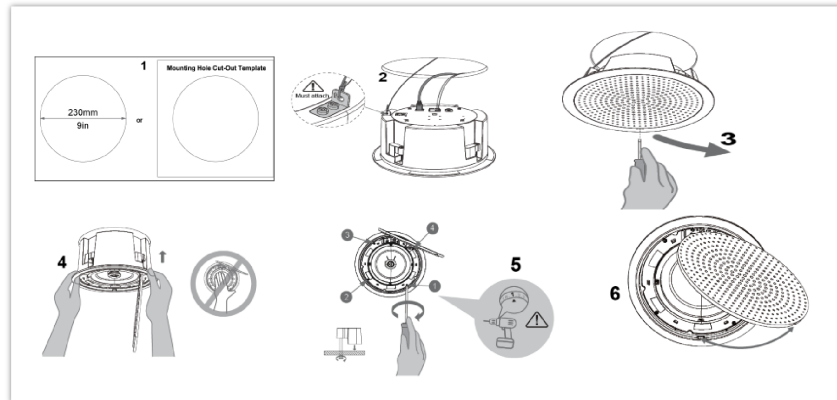

*Ceiling Mount*

## Boom Mount

1. Fix the Boom in the ceiling.
2. To ensure safety, install first the anti-fall ropes.
3. Attach the Boom with the GSC3506 ceiling hole and rotate to fix it in place.
4. Plug in the Ethernet and 2-pin cables.

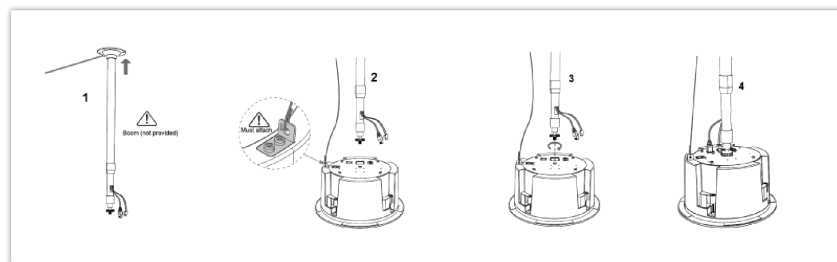

*Boom Mount*

## GSC3506 V2 Hardware installation

GSC3506 V2 can be mounted on the ceiling or the Boom. Please refer to the following steps for the appropriate installation.

### Ceiling Mount

1. Drill a round hole with a diameter of 230mm or use the Mounting Hole Cut-Out Template.
2. To ensure safety, install first the anti-fall ropes, then plug in the Ethernet and 2-pin cables.
3. Open the front cover with a flat-head screwdriver.
4. Align the device with the hole and push up slowly with two hands. (Avoid pressing the horn with your hands)
5. Use a screwdriver and gently rotate clockwise the screws marked as (1), (2), (3) and (4) in the step 5 illustration. (If you use an electric drill, make sure to adjust it to the minimum speed gear first)
6. Align the notch on the front cover with the notch on the device, press the whole front cover to ensure that each buckle is fastened



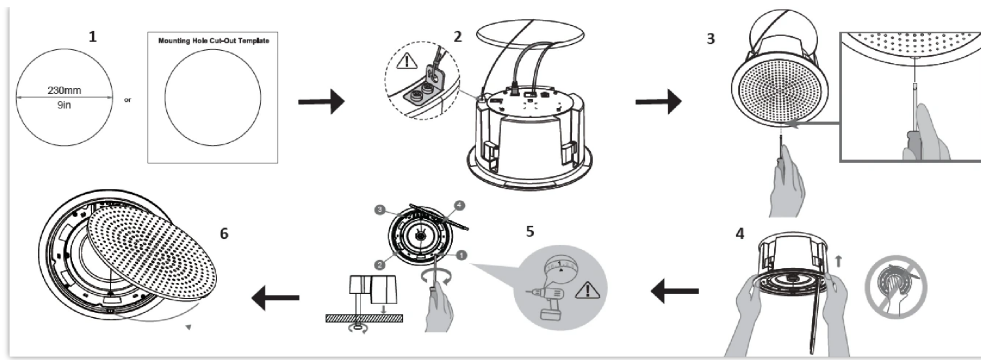

GSC3506 V2 Ceiling Mount

### Boom Mount

1. Fix the Boom in the ceiling.
2. To ensure safety, install first the anti-fall ropes. (The anti-fall rope diameter must be less than 5mm, and the pulling force must be greater than 25kgf)
3. Attach the Boom with GSC3506 V2 ceiling hole and rotate to fix it in place.
4. Plug in the Ethernet and 2-Pin 24V Power Supply cable.

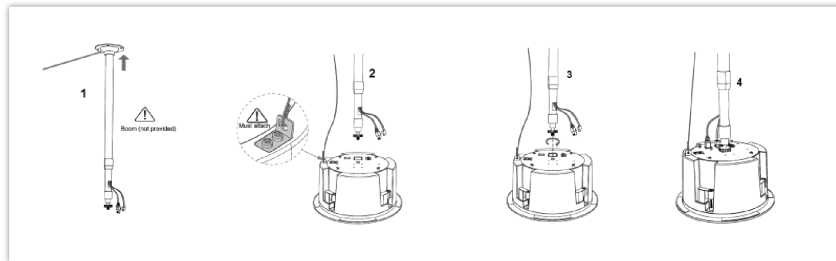

GSC3506 V2 Boom Mount

### Powering and Connecting GSC3516

The GSC3516 can be powered on using PoE/PoE+ switch or PoE injector using the following steps:

- o **Step 1:** Plug an RJ45 Ethernet cable into the network port of the GSC3516.
- o **Step 2:** Plug the other end into the power over Ethernet (PoE) switch or PoE injector.

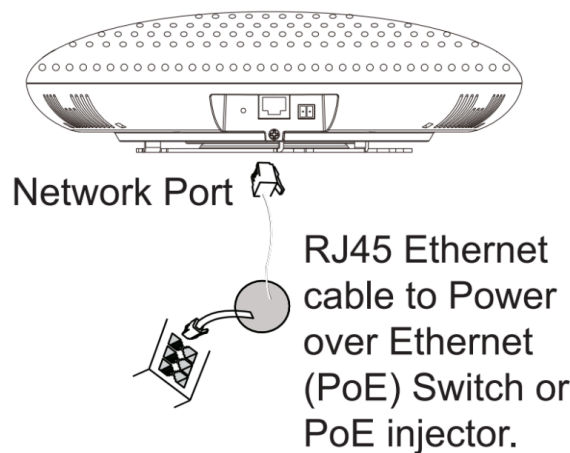

Powering GSC3516

### Connecting Wiring Seat for GSC3516

GSC3516 support to connect a "Key & LED" or "Normal Key" to the 2-pin port via Wiring Seat using the following steps:

- o **Step 1:** Take the wiring seat from the install kits.
- o **Step 2:** Connect the "Key & LED" or "Normal Key" with the wiring seat (as shown in the figure below)

**Note:** This port supports the parallel connection of an incandescent lamp (with less than 1W) or an LED lamp (with less than 100mA).

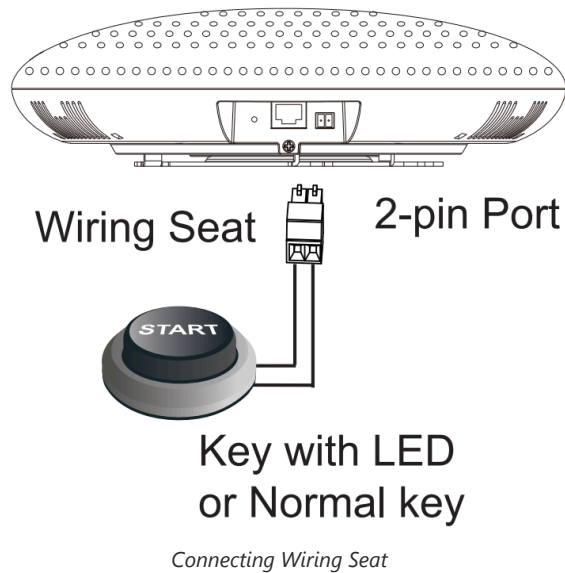

## Powering and Connecting GSC3506

GSC3506 can be powered on using PoE/PoE+ switch or PoE injector using the following steps:

**Step 1:** Plug an RJ45 Ethernet cable into the network port of the GSC3506.

**Step 2:** Plug the other end into the power over Ethernet (PoE) switch or PoE injector.

### Note

It is recommended to use PoE+ power supply to achieve the best audio effect.

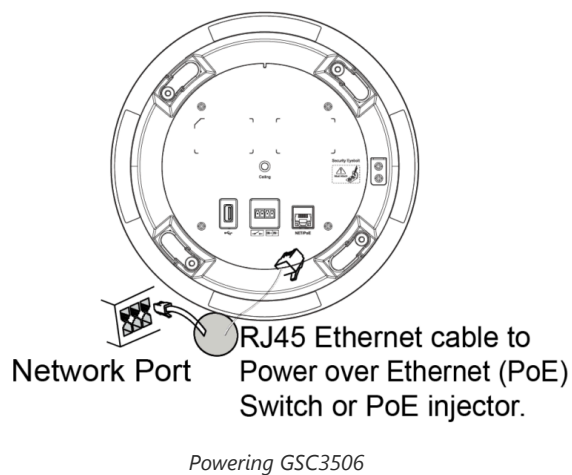

## Connecting Wiring Seat for GSC3506

GSC3506 support connecting a "Normal Key" to a 2-pin port via Wiring Seat.

**Step 1:** Take the wiring seat from the install kits.

**Step 2:** Connect the Normal Key with the wiring seat (as shown in the illustration below).

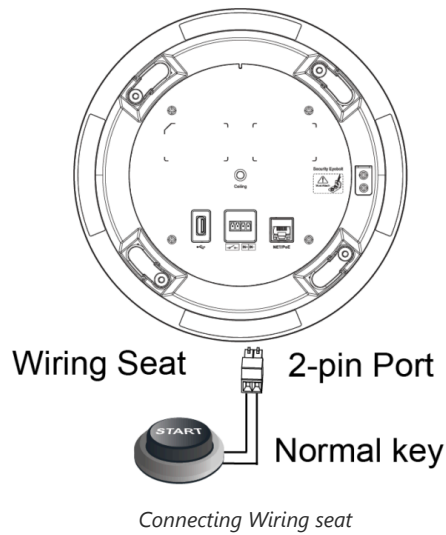

## Powering and Connecting GSC3506 V2

GSC3506 V2 can be powered on using PoE/PoE+/ PoE++ switch or connecting the 2-Pin 24V Power Supply cable.

### Using PoE Switch

**Step 1:** Plug a RJ45 Ethernet cable into the network port of the GSC3506 V2.

**Step 2:** Plug the other end into the power over Ethernet (PoE++) switch or PoE injector.

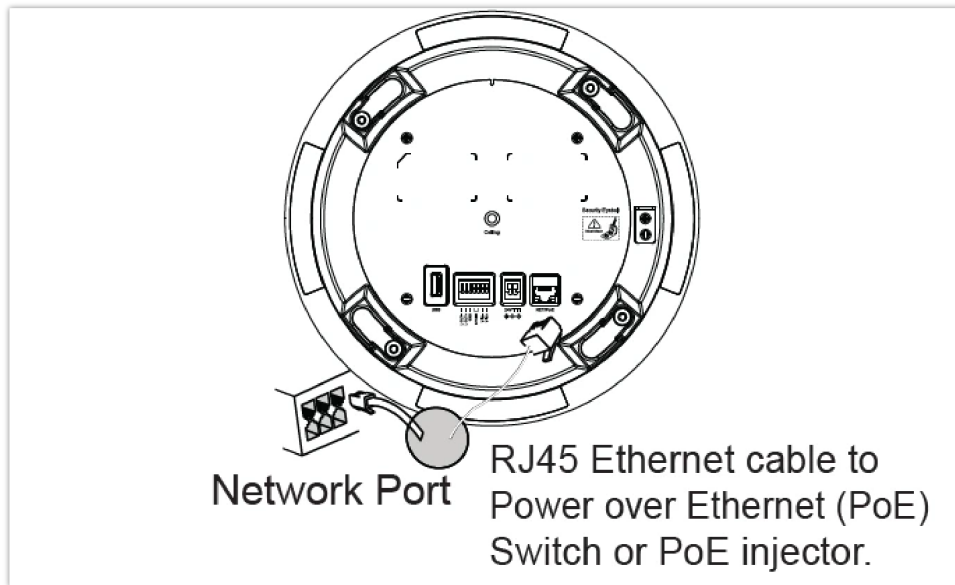

*Powering GSC3506 V2 using PoE*

**Note:**

It is recommended to use PoE++ power supply to achieve the best audio effect.

### Using 2-Pin 24V Power Supply

Connect a 2-Pin 24V Power Supply cable with the 2-Pin 24V Power Supply Port (as shown in the illustration on the right).

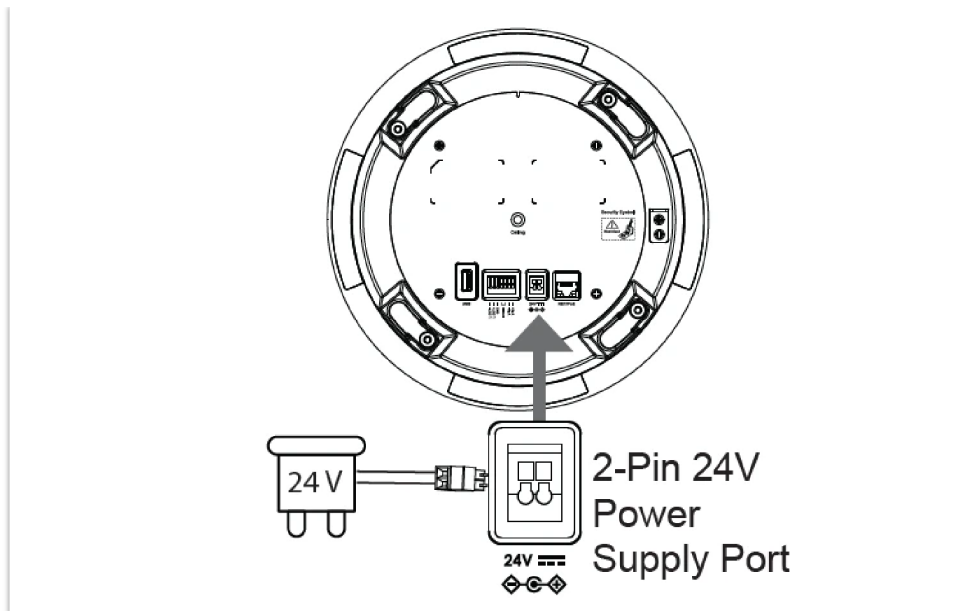

*Powering GSC3506 V2 using Power Supply*

**Note:**

To connect GSC3506 V2 to the local network, RJ45 Ethernet cable needs to be connected too.

### Access GSC35x6 (V2) Web GUI

The GSC3516/GSC3506/GSC3506 V2 embedded Web server responds to HTTP/HTTPS GET/POST requests. Embedded HTML pages allow users to configure the application phone through a Web browser such as Microsoft's IE, Mozilla Firefox, Google Chrome and etc.



*GSC3516 Web GUI – Login*

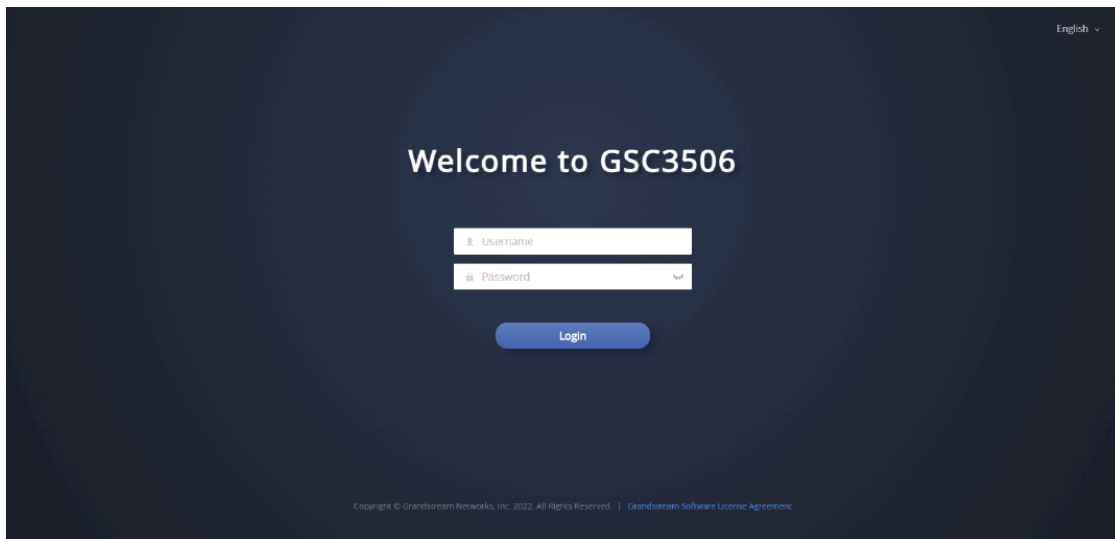

### GSC3506 Web GUI – Login

Users can use a computer connected to the same network as the GSC3516/GSC3506/GSC3506 V2 to discover and access the GSC3516/GSC3506/GSC3506 V2 Configuration Interface using its MAC Address.

Please, refer to the following steps in order to access the GSC3516/GSC3506/GSC3506 V2 Web GUI:

1. Locate the MAC address on the MAC tag of the unit, which is on the underside of the device, or on the package.
2. From a computer connected to the same network as the GSC3516/GSC3506/GSC3506 V2, type in the following address using the GSC3516/GSC3506/GSC3506 V2's MAC address on your browser: **https://gsc\_<mac>.local**

**Example:** if a GSC3516/GSC3506/GSC3506 V2 has the MAC address C0:74:AD:xx:xx:xx, this unit can be accessed by typing [https://gsc\\_c074adxxxxxx.local](https://gsc_c074adxxxxxx.local) on the browser.

## GSC35x6 (V2) APPLICATION SCENARIOS

### GSC3516 SIP Multicom Intercom System

GSC3516 can be used as an Intercom System using built-in SIP accounts, once the SIP account is registered the device can receive paging/intercom calls and it will automatically answer calls coming from whitelisted numbers.

While the GSC3506 works as a 1-way SIP speaker with a built-in Intercom system.

To register a SIP account on the GSC3516/GSC3506/GSC3506 V2 the user needs to go under **Account → Account X → General Settings**, and enter the account information as below, then save and apply the configuration.

SIP Account Configuration

Once the account is registered correctly, the GSC3516/GSC3506/GSC3506 V2 will show the account status under **Status** → **Account Status**.

Account	SIP User ID	SIP Server	Operation
Account 1	2001	192.168.5.116	
Account 2			
Account 3			

SIP Account Status

By default, the GSC3516/GSC3506/GSC3506 V2 Blocks non-whitelisted numbers under **Calls** → **Blacklist/Whitelist/Greylis** → **Greylist**, user needs to either allow Non-White list calls or set up a Whitelist that contains the number that will be allowed to call the GSC3516/GSC3506/GSC3506 V2.

Greylist Calls

On the screenshot below, only number 1001 is allowed to call GSC3516/GSC3506/GSC3506 V2:

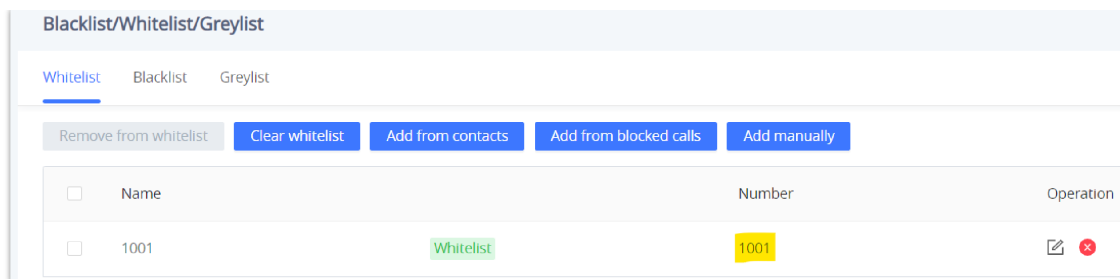

*Whitelisted Devices*

As soon as a SIP call is received by the GSC3516/GSC3506/GSC3506 V2, it first checks if the Caller ID number is allowed on the Whitelist and then answers automatically.

### Notes

- GSC3516 is an intercom system and auto-answers all whitelisted numbers.
- By default, GSC3516 plays a Warning tone when auto-answering incoming calls, this warning tone can be disabled under **Account → Account X → Call Settings**, "Play Warning Tone for Auto Answer Intercom".

## Multicast Paging Application

Multicast paging is an approach to let different SIP users listen for paging calls from a common multicast IP address. In multicast page calls, an audio connection will be set up from sender to receiver, but the receiver will be only able to receive audio, a one-way communication. The 2 entities, Sender/Receiver, must be located on the same LAN (same broadcast domain).

To receive a multicast page, GSC3516/GSC3506/GSC3506 V2 must be well configured to listen to the right address and port. The configuration is located under **Phone Settings → Multicast/Group Paging**. Up to 10 listening addresses are supported with priority levels from 1 to 10.

**Note:** Multicast paging configuration requires a reboot to take effect.

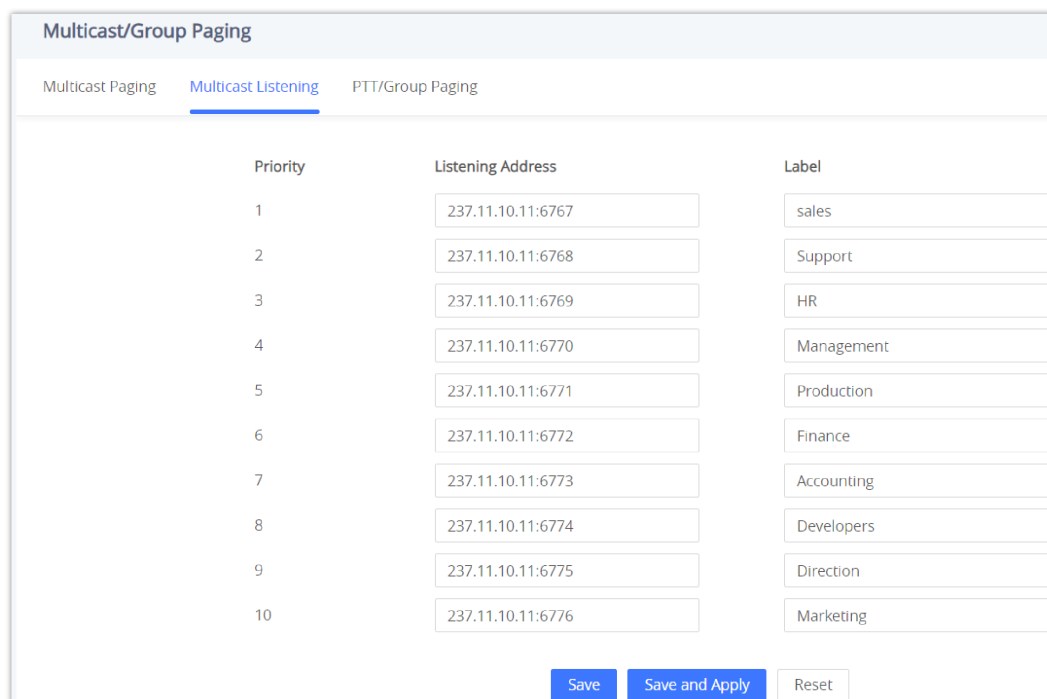

*Multicast Paging Listening Addresses*

In the above screenshot, the Listening Address "237.11.10.11:6767" with the label "Sales" has the highest priority.

Users can enable the "Paging Priority Active" option (under the Multicast Paging tab) to accept incoming paging calls during active multicast paging. The paging call with a higher priority than the active one will be accepted.

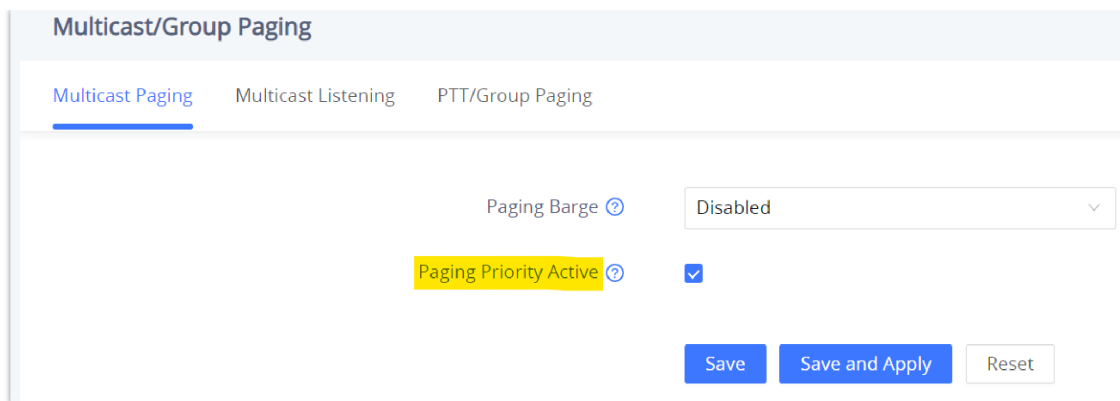

Multicast Paging – Paging Priority Active

In the case of receiving a multicast paging call while on a unicast SIP call, the GSC3516/GSC3506/GSC3506 V2 can choose to either keep the SIP call or hold this last and allow the multicast call depending on the paging call priority.

This can be set using the "Paging Barge" option. If the option is set to "Disabled" all incoming multicast paging calls will be dropped while on a SIP call. If the multicast paging call has higher priority than the value set on "Paging Barge", the SIP call will be put on hold and GSC3516/GSC3506/GSC3506 V2 will be the incoming multicast paging.

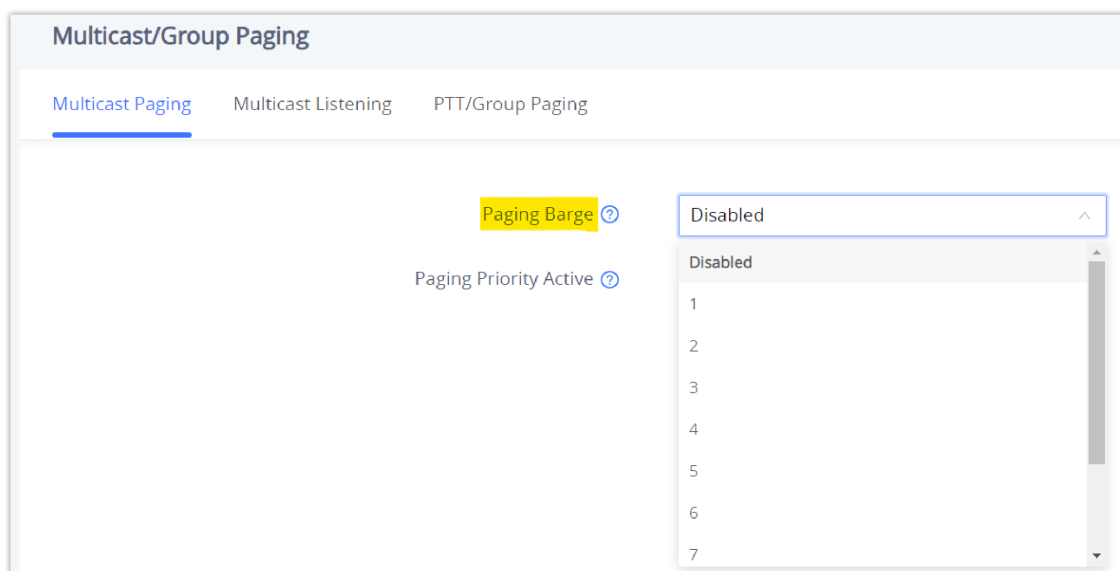

Figure 15: Multicast Paging – Priority Barge

**Note**

The start and end of multicast tones have been removed from the multicast configuration starting from firmware 1.0.3.4

## Bluetooth Speaker

**Note**

The bluetooth feature is available only on the GSC3516 Speaker model.

The GSC3516 can be used as a Bluetooth speaker for another device and it needs to be connected via Bluetooth to that device. Users need to turn on GSC3516's Bluetooth function first. The first time when using a new Bluetooth device with the GSC3516, "pair" the device with GSC3516 so that both devices know how to connect securely to each other.



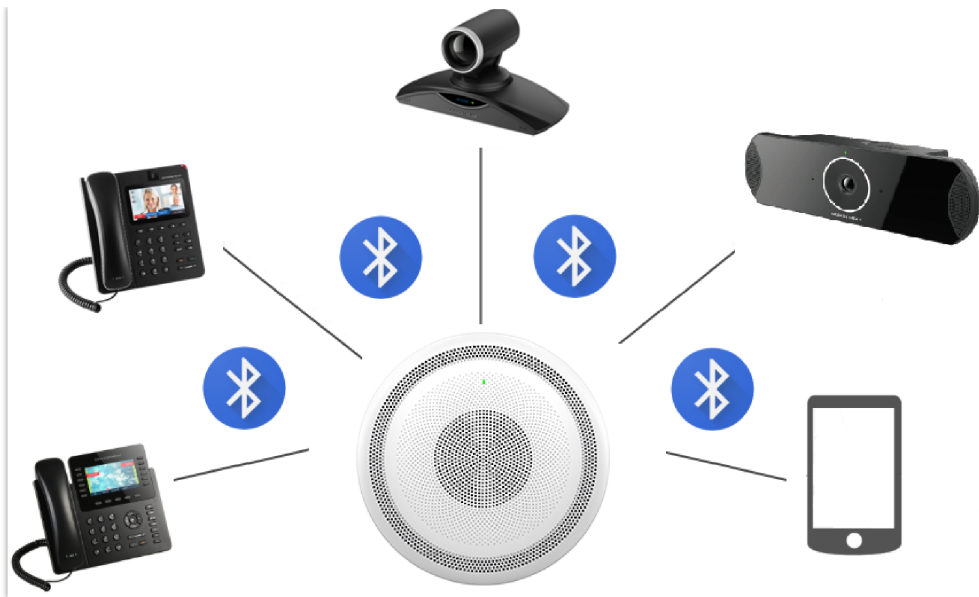

*Connecting the GSC3516 as a Bluetooth Speaker*

Please, refer to the following steps in order to pair and connect the GSC3516 to the device:

1. Go to GSC3516 **Web GUI** → **Network Settings** → **Bluetooth**.
2. Enable the "Bluetooth" function, and enable the option "Discoverable to Nearby Bluetooth Devices" in order to make the GSC3516 visible.
3. Go to your Device's Bluetooth settings in order to search for visible devices. The GSC3516 is going to be listed within the visible devices with the "Device Name" configured on the Web GUI.
4. Click on the GSC3516 device's name in order to pair and connect it to the device.

**Note**

- o The GSC3516 will play the role of a 2-way intercom speaker when connected to another device via Bluetooth.
- o Users cannot use the GSC3516 to control calls made/received by the device connected to it, all the phone operations needs to be done on the device itself.

**2-pin Multi-Purpose Input Applications**

GSC3516 supports 2-pin multi-purpose input that can connect a "Key with LED" or "Normal Key". By configuring the sensor settings users can enable the GSC3516 to play an audio file (.wav/.mp3 format), and trigger a SIP call to a pre-configured extension.

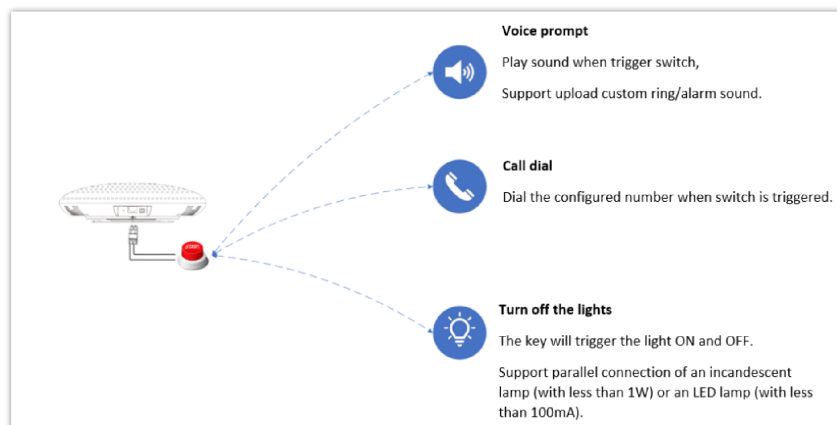

*2-pin Multi-Purpose Input Applications for GSC3516*

While the GSC3506 supports connecting a "Normal Key" to a 2-pin port via Wiring Seat, By configuring the sensor settings users can enable the GSC3506 to play an audio file (.wav/.mp3 format), and trigger a SIP call to a pre-configured extension, The GSC3506 Model also supports a separate Alarm-in input port (Access voltage 5V to 12V).



*2-pin Multi-Purpose Input Applications for GSC3506*

To configure sensor settings on Both GSC3516/GSC3506/GSC3506 V2, access **web UI → System Settings → Sensor Setting**.

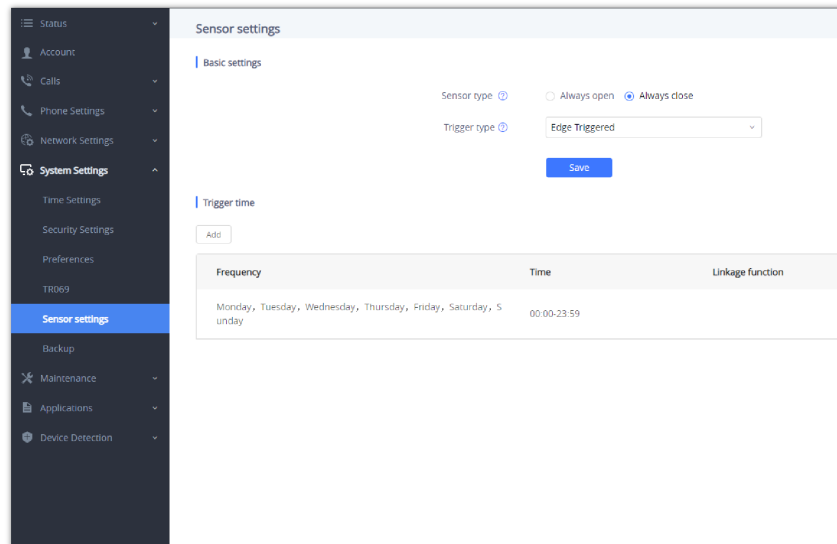

*Sensor Settings*

Under the Basic Setting section, users can set "Sensor Type" and "Trigger Type".

Two states are supported by the Input circuit for the "Sensor Type":

1. **Normally Open** where the contact is disconnected when there is no electricity
2. **Normally Close** where the contact is connected when there is no electricity.

Users could set "Trigger Type" to:

1. **Edge Triggered:** When selected, the notification is triggered only when the level changes (high level to a low level, or low level to a high level).
2. **Level Triggered:** When selected, only high level (1) will trigger the notification.

Under the "Trigger time" section, users can click on "Add" in order to configure different schedules and a trigger profile for each one as shown in the figure below:

Trigger time

Cycle Time  All days  Period of Time

Time  —

Frequency

Play audio

Make call

recording

Frequency	Time	Linkage function	Operation
Monday	11:48-15:48	Play audio, Make call, recording	<input type="checkbox"/> <input type="checkbox"/>
Tuesday, Saturday	09:50-11:48	Play audio	<input type="checkbox"/> <input type="checkbox"/>
Wednesday	11:48-15:53	Play audio, recording	<input type="checkbox"/> <input type="checkbox"/>

Sensor Setting – Trigger time

- **Cycle Time:** The alarm can be configured to be triggered all days of the week, in this case, the “All days” option needs to be checked. Or to some specific days of the week with Start and End times, in this case, the “**Period of Time**” option needs to be checked for users to be able to configure **Time** and **Frequency** options.
- **Play Audio:** If checked, GSC3516 will play a sound when the switch is triggered during the schedule. Users can select a “Prompt Tone” from available tones or upload a customized tone.

Cycle Time  Daily  Period of Time

Time

Frequency

Play Audio

Prompt Tone

Make Call

Hang Up

Recording

Sensor Setting – Linkage Function – Play Audio

- **Make Call:** If checked, GSC3516/GSC3506/GSC3506 V2 will dial out configured numbers on the “Dial out extension” fields (up to 2 numbers supported) when the switch is triggered during the schedule.

Play Audio ?	<input checked="" type="checkbox"/>
Prompt Tone ?	System Ringtone
Make Call ?	<input checked="" type="checkbox"/>
Dial Out Extension ?	<input type="text" value="2000"/> <input type="button" value="-"/> <input type="text" value="2002"/> <input type="button" value="-"/>
Hang Up ?	<input type="checkbox"/>
Recording ?	<input type="checkbox"/>

*Sensor Setting – Linkage Function – Make Call*

**Note**

Up to 7 different Alarm Schedule/Linkage function can be configured in the GSC3516, the list of schedules and linkage functions will be shown in the lower section of the page, users can edit or delete the Alarm schedule by clicking on **Edit** or **Delete** buttons respectively.

## GSC35x6 (V2) WEB GUI SETTINGS

The GSC35x6 (V2) embedded Web server responds to HTTP/HTTPS GET/POST requests. Embedded HTML pages allow users to configure the application phone through a Web browser such as Microsoft’s IE, Mozilla, Firefox, Google Chrome and etc.

### Status Page Definitions

#### Account Status

<b>Account</b>	16 SIP accounts on the device
<b>SIP User ID</b>	SIP User ID for the account
<b>SIP Server</b>	SIP Server Address
<b>Operation</b>	Edit the account details.

*Account Status*

#### Network Status

##### Network Status – Ethernet

<b>LAN Port</b>	Displays LAN Port connected or not and the speed
<b>MAC Address</b>	Global unique ID of device, in HEX format. The MAC address will be used for provisioning and can be found on the label coming with original box and on the label located on the back of the device.

<b>PPPoE Link Up</b>	PPPoE status: Enabled or Disabled
<b>IPv4</b>	
<b>IPv4 Address Type</b>	Configured IPv4 address type: DHCP, Static IP or PPPoE
<b>IPv4 Address</b>	IPv4 address of the device.
<b>Gateway</b>	Default gateway of the device.
<b>IPv4 NAT Type</b>	Type of IPv4 NAT connection used by the device.
<b>IPv6</b>	
<b>IPv6 Address Type</b>	Configured IPv6 address type: DHCP, Static IP or PPPoE
<b>Global Unicast Address</b>	IPv6 address of the device.
<b>Link-Local Address</b>	Link-Local Address of the device
<b>IPv6 Static Gateway</b>	Default IPv6 gateway of the device.
<b>IPv6 DUID</b>	IPv6 DUID of the device.
<b>IPv6 NAT Type</b>	Type of IPv6 NAT connection used by the device.

*Status – Network Status – Ethernet page*

**Network Status – Wi-Fi ( Available only on GSC3516 )**

<b>WLAN MAC Address</b>	Device WLAN MAC Address
<b>SSID</b>	Displays the name of the SSID currently the device connected to
<b>Country Code</b>	The configured Country Code
<b>IPv4</b>	
<b>IPv4 Address Type</b>	Configured IPv4 address type: DHCP, Static IP or PPPoE
<b>IPv4 Address</b>	IPv4 address of the device.
<b>Gateway</b>	Default gateway of the device.
<b>IPv4 NAT Type</b>	Type of IPv4 NAT connection used by the device.
<b>IPv6</b>	
<b>IPv6 Address Type</b>	Configured IPv6 address type: DHCP, Static IP or PPPoE
<b>Global Unicast Address</b>	IPv6 address of the device.
<b>Link-Local Address</b>	Link-Local Address of the device

<b>IPv6 Static Gateway</b>	Default IPv6 gateway of the device.
<b>IPv6 DUID</b>	IPv6 DUID of the device.
<b>IPv6 NAT Type</b>	Type of IPv6 NAT connection used by the device.

*Status – Network Status – Wi-Fi page*

## Network Status → DNS & NAT

<b>DNS Server</b>	
<b>DNS Server x</b>	DNS Server Address up to 4 address (ex: 8.8.8.8)
<b>DNS Mode</b>	
<b>Accounts x</b>	DNS Mode for each SIP Account up to 16 accounts: A Record, SRV, NAPTR/SRV, Use Configured IP
<b>NAT Traversal</b>	
<b>Accounts x</b>	NAT Traversal for each SIP Account up to 16 accounts: No, STUN, Keep-Alive, UPnP, Auto, VPN (Auto is the default settings)

*Status – Network Status – DNS & NAT page*

## System Info

### System Info → Information

<b>Product Model</b>	Product model of the device: GSC3516
<b>Part Number</b>	Product part number
<b>Software Version</b>	
<b>Boot</b>	Specifies Boot version
<b>Core</b>	Specifies Core version
<b>Prog</b>	Specifies Prog version. This is the main firmware release number, which is always used for identifying the software system
<b>Locate</b>	Specifies Locale version
<b>Res</b>	Specifies Locale version
<b>IP Geographic Information</b>	
<b>Language</b>	Specifies current language
<b>Recommend Time Zone</b>	Specifies Recommend Time Zone
<b>System Time</b>	

<b>System Up Time</b>	System up time since the last reboot
<b>System Time</b>	Indicates Date and Time
<b>System Time Zone</b>	Indicates the Time Zone selected
<b>PoE Detection</b>	
<b>PoE Status</b>	Indicates POE Status: Type and Max wattage
<b>System Information</b>	
<b>Download System Information</b>	Click on "Download" to download a file containing all the system information

*System Info – Information page*

### System Info → Status

<b>Service Status</b>	
<b>gui</b>	Indicates gui code
<b>phone</b>	Indicates phone code
<b>cpe</b>	Indicates cpe code
<b>avs</b>	Indicates avs code
<b>User Space</b>	
<b>User Space Used</b>	Indicates User space used
<b>Database Status</b>	Indicates the status of the Database (ex: Normal)
<b>Core Dump</b>	
<b>Generate core dump</b>	Click on (GUI, AVS, CPE, PHONE) to generate a core dump
<b>Core Dump</b>	Click on "Download" to download the generated core dump
<b>Clear Core Dumps</b>	Click on "Start" to clear Core Dumps files
<b>Special Feature</b>	
<b>OpenVPN® Support</b>	Indicates the support of OpenVPN® (Yes)

*System Info – Status page*

### Account Page Definitions

GSC35x6 (V2) has 16 independent SIP accounts. Each SIP account has an individual configuration page.

### Accounts/General Settings

<b>Account Register</b>	
<b>Account Active</b>	Indicates whether the account is active. 1st account active by default.
<b>Account Name</b>	Configures the name associated with each account.
<b>IP Server</b>	Specifies the URL or IP address, and port of the SIP server. This should be provided by VoIP service provider (ITSP).
<b>Secondary SIP Server</b>	The URL or IP address, and port of the SIP server. This will be used when the primary SIP server fails.
<b>Outbound Proxy</b>	Configures the IP address or the domain name of the primary outbound proxy, media gateway or session border controller. It's used by the device for firewall or NAT penetration in different network environments. If a symmetric NAT is detected, STUN will not work and only an outbound proxy can provide a solution
<b>Secondary Outbound Proxy</b>	Sets IP address or domain name of the secondary outbound proxy, media gateway or session border controller. The device will try to connect the Secondary outbound proxy only if the primary outbound proxy fails.
<b>SIP User ID</b>	Configures user account information provided by your VoIP service provider (ITSP). It's usually in the form of digits similar to phone number or actually a phone number.
<b>SIP Authentication ID</b>	Configures the SIP service subscriber's Authenticate ID used for authentication. It can be identical to or different from the SIP User ID.
<b>SIP Authentication Password</b>	Configures the account password required for the device to authenticate with the ITSP (SIP) server before the account can be registered. After saving, it will appear as hidden for security purpose
<b>Display Name</b>	Configures the subscriber's name (optional) that will be used for Caller ID display.
<b>Tel URI</b>	<p>Indicates E.164 number in "From" header by adding "User=Phone" parameter or using "Tel:" in SIP packets, if the device has an assigned PSTN Number.</p> <ul style="list-style-type: none"> <li>● <b>Disabled:</b> Will use "SIP User ID" information in the Request-Line and "From" header.</li> <li>● <b>User=Phone:</b> "User=Phone" parameter will be attached to the Request-Line and "From" header in the SIP request to indicate the E.164 number. If set to "Enable".</li> <li>● <b>Enabled:</b> "Tel:" will be used instead of "sip:" in the SIP request.</li> </ul> <p><i>Please consult your carrier before changing this parameter. Default is "Disabled".</i></p>
<b>Network Settings</b>	
<b>DNS Mode</b>	<p>Defines which DNS service will be used to lookup IP address for SIP server's hostname. There are 4 modes:</p> <ul style="list-style-type: none"> <li>● A Record</li> <li>● SRV</li> <li>● NATPTR/SRV</li> <li>● User Configured IP</li> </ul> <p><i>To locate the server by DNS SRV set this option to "SRV" or "NATPTR/SRV". Default setting is "A Record".</i></p>
<b>NAT Traversal</b>	<p>Specifies which NAT traversal mechanism will be enabled on the device. It can be selected from the dropdown list:</p> <ul style="list-style-type: none"> <li>● No</li> <li>● STUN</li> <li>● Keep-Alive</li> </ul>



	<ul style="list-style-type: none"> <li>● UPnP</li> <li>● Auto</li> <li>● VPN</li> </ul> <p>If the outbound proxy is configured and used, it can be set to “NAT NO”.</p> <p>If set to “STUN” and STUN server is configured, the device will periodically send STUN message to the STUN server to get the public IP address of its NAT environment and keep the NAT port open. STUN will not work if the NAT is symmetric type.</p> <p>If set to “Keep-alive”, the device will send the STUN packets to maintain the connection that is first established during registration of the device. The “Keep-alive” packets will fool the NAT device into keeping the connection open and this allows the host server to send SIP requests directly to the registered phone.</p> <p>If it needs to use OpenVPN to connect host server, it needs to set it to “VPN”. If the firewall and the SIP device behind the firewall are both able to use UPNP, it can be set to “UPNP”. The both parties will negotiate to use which port to allow SIP through. The default setting is “Keep-alive”. <i>The default settings is "Auto"</i></p>
<b>Proxy-Require</b>	Adds the Proxy-Required header in the SIP message. It is used to indicate proxy-sensitive features that must be supported by the proxy. Do not configure this parameter unless this feature is supported on the SIP server.

*Accounts – General Settings page*

## Accounts/SIP Settings

<b>Basic Settings</b>	
SIP Registration	Allows the device to send SIP REGISTER messages to the proxy/server. <i>The default setting is “Yes”.</i>
UNREGISTER on Reboot	If set to "No", the device will not unregister the SIP user's registration information before new registration. If set to "All", the SIP Contact header will use "*" to clear all SIP user's registration information. If set to "Instance", the device only needs to clear the current SIP user's info
REGISTER Expiration	Configures the time period (in minutes) in which the device refreshes its registration with the specified registrar. The default setting is 60. <i>The maximum value is 64800 (about 45 days).</i>
SUBSCRIBE Expiration	Specifies the frequency (in minutes) in which the device refreshes its subscription with the specified register. <i>The maximum value is 64800 (about 45 days).</i>
Re-Register before Expiration	Specifies the time frequency (in seconds) that the device sends re-registration request before the Register Expiration. The default setting is 0. <i>The range is from 0 to 64,800.</i>
Registration Retry Wait Time	Configures the time period (in seconds) in which the device will retry the registration process in the event that is failed. The default setting is 20. <i>The maximum value is 3600 (1 hour).</i>
Add Auth Header on Initial REGISTER	If enabled, the device will add Authorization header in initial REGISTER request.
Enable OPTIONS Keep-Alive	Enables SIP OPTIONS to track account registration status so the device will send periodic OPTIONS message to server to track the connection status with the server. <i>The default setting is “No”.</i>
OPTIONS Keep-Alive Interval	Configures the time interval when the device sends OPTIONS message to SIP server. The default value is 30 seconds, in order to send an OPTIONS message to the server every 30 seconds. <i>The default range is 1-64800.</i>

OPTIONS Keep-Alive Max Tries	Configures the maximum times of sending OPTIONS message consistently from the device to server. Device will keep sending OPTIONS messages until it receives response from SIP server. The default setting is "3", which means when the device sends OPTIONS message for 3 times, and SIP server does not respond this message, the device will send RE-REGISTER message to register again. <i>The valid range is 3-10.</i>
SUBSCRIBE for Registration	When set to "Yes", a SUBSCRIBE for Registration will be sent out periodically.
Use Privacy Header	Controls whether the Privacy header will present in the SIP INVITE message or not, whether the header contains the caller info: <ul style="list-style-type: none"> <li>● If set to "Yes", the Privacy Header will always show in INVITE</li> <li>● If set to "No", the Privacy Header will not show in INVITE.</li> </ul>
Use P-Preferred-Identity Header	Controls whether the P-Preferred-Identity header will present in the SIP INVITE message or not, whether the header contains the caller info: <ul style="list-style-type: none"> <li>● If set to "Yes", the P-Preferred-Identity Header will always show in INVITE</li> <li>● If set to "No", the P-Preferred-Identity Header will not show in INVITE</li> </ul>
Add MAC in User-Agent	If set to "Yes except REGISTER", all outgoing SIP messages will include the device's MAC address in the User-Agent header, except for REGISTER and UNREGISTER. If set to "Yes to All SIP", all outgoing SIP messages will include the device's MAC address in the User-Agent header. If set to "No", the device's MAC address will not be included in the User-Agent header in any outgoing SIP messages.
SIP Transport	Determines which network protocol will be used to transport the SIP message. It can be selected from TCP/UDP/TLS. <i>Default setting is "UDP".</i>
Enable TCP Keep-alive	Configures whether to enable TCP Keep-alive for the TCP connection between the terminal and the SIP server.
Local SIP Port	Determines the local SIP port used to listen and transmit. The default setting is 5060 for Account 1, 5062 for Account 2, 5064 for Account 3, 5066 for Account 4, 5068 for Account 5, and 5070 for Account 6. <i>The valid range is from 5 to 65535.</i>
SIP URI Scheme When Using TLS	Defines which SIP header, "sip" or "sips", will be used if TLS is selected for SIP Transport. <i>The default setting is "sip".</i>
Use Actual Ephemeral Port in Contact with TCP/TLS	Determines the port information in the Via header and Contact header of SIP message when the device use TCP or TLS. If set to No, these port numbers will use the permanent listening port on the device. Otherwise, they will use the ephemeral port for the particular connection. <i>The default setting is "No".</i>
Support SIP Instance ID	Determines if the device will send SIP Instance ID. The SIP instance ID is used to uniquely identify the device. If set to "Yes", the SIP Register message Contact header will include +sip.instance tag. <i>Default is "Yes".</i>
SIP T1 Timeout	Defines an estimate of the round-trip time of transactions between a client and server. If no response is received in T1, the figure will increase to 2*T1 and then 4*T1. The request re-transmit retries would continue until a maximum amount of time define by T2. <i>The default setting is 0.5 sec.</i>
SIP T2 Timeout	Specifies the maximum retransmit time of any SIP request messages (excluding the SIP INVITE message). The re-transmitting and doubling of T1 continues until it reaches the T2 value. <i>The default setting is 4 sec.</i>
SIP Timer D Interval	Defines the amount of time that the server transaction can remain when unreliable response (3xx-6xx) received. The valid value is 0-64 seconds.

	<i>The default value is 0.</i>
Outbound Proxy Mode	Configures whether to put the Outbound Proxy in the Route header, or if SIP messages should always be sent to Outbound Proxy.
Enable 100rel	Activates PRACK (Provisional Acknowledgment) method. PRACK improves the network reliability by adding an acknowledgement system to the provisional Responses (1xx). It is set to “Yes”, the device will response to the 1xx response from the remote party. <i>Default is “No”.</i>
<b>Session Timer</b>	
Enable Session Timer	Allows the device to use the session timer, when set to “Yes”, it will be added in the SIP INVITE message to notify the server.
Session Expiration	<p>Configures the device’s SIP session timer. It enables SIP sessions to be periodically “refreshed” via a SIP request (UPDATE, or re-INVITE). If there is no refresh via an UPDATE or re-INVITE message, the session will be terminated once the session interval expires.</p> <p>Session Expiration is the time (in seconds) where the session is considered timed out, provided no successful session refresh transaction occurs beforehand.</p> <p>The default setting is 180. The valid range is from 90 to 64800.</p>
Min-SE	Determines the minimum session expiration timer (in seconds) if the device act as a timer refresher. Default is 90. <i>The valid range is from 90 to 64800.</i>
Caller Request Timer	Sets the caller party to act as refresher by force. If set to “Yes” and both party support session timers, the device will enable the session timer feature when it makes outbound calls. The SIP INVITE will include the content “refresher=uac”. <i>The default setting is “No”.</i>
Callee Request Timer	Sets the callee party to act as refresher by force. If set to “Yes” and the both parties support session timers, the device will enable the session timer feature when it receives inbound calls. The SIP 200 OK will include the content “refresher=uas”. <i>The default setting is “No”.</i>
Force Timer	<p>Configures the session timer feature on the device by force.</p> <ul style="list-style-type: none"> <li>● If it is set to “Yes”, the device will use the session timer even if the remote party does not support this feature.</li> <li>● If set to “No”, the device will enable the session timer only when the remote party supports this feature. To turn off the session timer, select “No”.</li> </ul> <p><i>The default setting is “No”.</i></p>
UAC Specify Refresher	As a caller, select UAC to use the device as the refresher, or select UAS to use the callee or proxy server as the refresher. When set to "Omit", the refresh object is not specified.
UAS Specify Refresher	As a callee, select UAC to use caller or proxy server as the refresher, or select UAS to use the device as the refresher.
Force INVITE	Sets the SIP message type for refresh the session. If it is set to “Yes”, the Session Timer will be refreshed by using the SIP INVITE message. Otherwise, the device will use the SIP UPDATE or SIP OPTIONS message. <i>Default is “No”.</i>

*Accounts – SIP Settings page*

## Accounts/Codec Settings

<b>Audio</b>
--------------

Preferred Vocoder	Lists the available and enabled Audio codecs for this account. Users can enable the specific audio codecs by moving them to the selected box and set them with a priority order from top to bottom. This configuration will be included with the same preference order in the SIP SDP message.
Codec Negotiation Priority	Configures the device to use which codec sequence to negotiate as the callee. When set to "Caller", the device negotiates by SDP codec sequence from received SIP Invite; When set to "Callee", the device negotiates by audio codec sequence on the device. <i>The default setting is "Callee".</i>
Use First Matching Vocoder in 200OK SDP	Configures the device to use the first matching codec in the 200OK message. <i>The default value is 0.</i>
iLBC Frame Size	Sets the iLBC (Internet Low Bitrate Codec) frame size if ILBC is used. Users can select it from 20ms or 30ms. <i>The default setting is 30ms.</i>
G.726-32 Packing Mode	Selects "ITU" or "IETF" for G.726-32 packing mode.
G.726-32 Dynamic Payload Type	Specifies the G726-32 payload type, and the valid range is 96 to 127. <i>The default setting is "127".</i>
Opus Payload Type	Defines the desired value (96-127) for the payload type of the Opus codec. <i>The default value is 123.</i>
Send DTMF	Specifies the mechanism to transmit DTMF digits. <ul style="list-style-type: none"> <li>● in-audio</li> <li>● via RTP (RFC2833)</li> <li>● via SIP INFO</li> </ul> The default settings: via RTP(RFC2833)
DTMF Payload Type	Configures the RTP payload type that indicates the transmitted packet contains DTMF digits. Valid range is from 96 to 127. <i>Default value is 101.</i>
Enable Audio RED with FEC	If set to "Yes", FEC will be enabled for audio call. <i>The default setting is "No".</i>
Audio FEC Payload Type	Configures audio FEC payload type. The valid range is from 96 to 127. <i>The default value is 121.</i>
Audio RED Payload Type	Configures audio RED payload type. The valid range is from 96 to 127. <i>The default value is 124.</i>
Silence Suppression	If set to "Yes", when silence is detected, a small quantity of VAD packets (instead of audio packets) will be sent during the period of no talking. For codec G.723 and G.729 only. <i>Default is not enabled</i>
Voice Frames per TX	Configures the number of voice frames transmitted per packet. When configuring this, it should be noted that the "ptime" value for the SDP will change with different configurations here. This value is related to the codec used and the actual frames transmitted during the in-payload call. For end users, it is recommended to use the default setting, as incorrect settings may influence the audio quality. <i>The default setting is 2.</i>
<b>RTP Settings</b>	
SRTP Mode	Sets if the device will enable the SRTP (Secured RTP) mode. It can be selected from dropdown list: <ul style="list-style-type: none"> <li>● No</li> <li>● Enabled but not forced</li> <li>● Enabled and forced</li> <li>● Optional</li> </ul> <i>The default setting is "No".</i>

SRTP Key Length	<p>Configures all the AES (Advanced Encryption Standard) key size within SRTP. It can be selected from dropdown list:</p> <ul style="list-style-type: none"> <li>• AES128&amp;256 bit</li> <li>• AES 128 bit</li> <li>• AES 256 bit</li> </ul> <p>If it is set to “AES 128&amp;256 bit”, the device will provide both AES 128 and 256 cipher suites for SRTP. If set to “AES 128 bit”, it only provides 128-bit cipher suite; if set to “AES 256 bit”, it only provides 256-bit cipher suite. <i>The default setting is “AES128&amp;256 bit”.</i></p>
Crypto Life Time	Configures whether to enable Crypto Life Time. <i>Default is "Disabled"</i>
RTCP Destination	Configures a remote server URI where RTCP messages will be sent to during an active call.
RTCP Keep-Alive method	<p>Configures the RTCP channel keep-alive packet type:</p> <ul style="list-style-type: none"> <li>• If set to "Receiver Report", the RTCP channel will sends "receiver report+source description+RTCP extension" as keep-alive dataReceiver Report</li> <li>• If set to "Sender report", the RTCP channel will sends "Sender report+source description+ RTCP extension" as keep-alive data.</li> </ul> <p><i>Default is "Receiver Report"</i></p>
RTP Keep-Alive method	<p>Configures the RTP channel keep-alive packet type..</p> <ul style="list-style-type: none"> <li>• If set to "No", no data will be sent</li> <li>• If set to "RTP version 1", the wrong version infor "1" will be carried when sending RTP data packets</li> </ul> <p><i>Default is "RTP Version 1"</i></p>
Symmetric RTP	<p>Configures if the device enables the symmetric RTP mechanism.</p> <p>If it is set to “Yes”, the device will use the same socket/port for sending and receiving the RTP messages. <i>The default setting is “No”.</i></p>
RTP IP Filter	<p>Receives the RTP packets from the specified IP address and Port by communication protocol. If it is set to “IP Only”, the device only receives the RTP packets from the specified IP address based on the communication protocol; If it is set to “IP and Port”, the device will receive the RTP packets from the specified IP address with the specified port based on the communication protocol.</p> <p><i>The default setting is “Disable”.</i></p>
RTP Timeout (s)	<p>Configures the RTP timeout of the GSC35xx. If the GSC does not receive an RTP packet within the specified RTP time, the call will be automatically disconnected. The default range is 6-600 seconds. If set to 0, this feature is disabled.</p> <p>Default value is 0.</p>

*Accounts – Codec Settings page*

## Accounts/Call Settings

<b>General</b>	
<b>Play warning tone for Auto Answer Intercom</b>	When this option is enabled, the device will play a warning tone When auto-answering intercom. The default setting is “yes”.
<b>Send Anonymous</b>	If set to “Yes”, the “From” header in outgoing INVITE messages will be set to anonymous, essentially blocking the Caller ID to be displayed.
<b>Anonymous Call Rejection</b>	If set to "Yes", anonymous calls will be rejected. <i>Default is "Disabled"</i>
<b>Call Log</b>	Categorizes the call logs saved for this account. If it is set to “Log All”, all the call logs of this account

	<p>will be saved.</p> <ul style="list-style-type: none"> <li>● If set to “Log Incoming/Outgoing Calls (Missed Calls Not Record)”, the whole call history will be saved other than missed call.</li> <li>● If it is set to “Disable Call All”, none of the call history will be saved. If it is set to “Don’t Prompt Missed Call”, the device will log the missed call histories, but there is no prompt to indicate the missed calls.</li> </ul> <p><i>The default setting is “Log All”.</i></p>
<b>Mute on Intercom Answer</b>	<p>If enabled, the phone will mute the microphone after answer an intercom call via Call-Info/Alert-Info. <i>Default is "Disabled"</i></p>
<b>Ring Timeout</b>	<p>Defines the expiration timer (in seconds) for the rings with no answer. <i>The default setting is 60.</i> The valid range is from 10 to 300.</p>
<b>Incoming Call Rules</b>	<p>Allow to set incoming call rules for each account registered. This configuration will over rule the global incoming call rules. If set to “Block”, all greylist calls will be blocked. If set to “Set password”, all greylist calls will need to enter the correct password before they can be answered. If set to “Auto answer”, all greylist calls will be automatically answered. If set to “Ringing”, all greylist calls will continue to ringing. The default ring time is 60s. <i>You can customize the timeout under the Account → Call setting → Ring timeout. The default value is “Disable”.</i></p>
<b>Dial Plan</b>	
<b>Dial Plan Prefix</b>	<p>This parameter can be configured to define the prefix added to each dialed number.</p>
<b>Bypass Dial Plan</b>	<p>Bypass dial plan on selected items:</p> <ul style="list-style-type: none"> <li>● Contact</li> <li>● Call History Incoming Call</li> <li>● Call History Outgoing Call</li> <li>● API</li> </ul> <p><i>Default is "Nothing is selected"</i></p>
<b>Dial Plan</b>	<p>Configures the dial plan to establish the expected number and pattern of digits for a telephone number. This parameter configures the allowed dial-plan for the device.</p> <p>Dial Plan Rules:</p> <ol style="list-style-type: none"> <li>1. Accepted Digits: 1,2,3,4,5,6,7,8,9,0 , *, #, A,a,B,b,C,c,D,d,+</li> <li>2. Grammar: x – any digit from 0-9;</li> </ol> <ul style="list-style-type: none"> <li>● xx+ or xx. – at least 2-digit numbers</li> <li>● xx – only 2-digit numbers</li> <li>● ^ – exclude</li> <li>● [3-5] – any digit of 3, 4, or 5</li> <li>● [147] – any digit of 1, 4, or 7</li> <li>● &lt;2=011&gt; – replace digit 2 with 011 when dialing</li> <li>●   – the OR operand</li> <li>● +- add + to the dialing number</li> </ul> <p><b>Example 1:</b> <i>{[369]11   1617xxxxxx}</i> Allow 311, 611, and 911 or any 10-digit numbers with leading digits 1617</p> <p><b>Example 2:</b> <i>{^1900x+   &lt;=1617&gt;xxxxxx}</i> Block any number of leading digits 1900 or add prefix 1617 for any dialed 7-digit numbers</p> <p><b>Example 3:</b> <i>{1xxx[2-9]xxxxx   &lt;2=011&gt;x+}</i> Allow any number with leading digit 1 followed by a 3-digit number, followed by any number between 2 and 9, followed by any 7-digit number OR allow any length of numbers with leading digit 2, replacing the 2 with 011 when dialed.</p> <p><b>Default:</b> <i>Outgoing – { x+   +x+   *x+   *xx*x+ }</i> Allow any number of digits, OR any number with a leading +, OR any number with a leading *, OR any number with a leading * followed by a 2-digit number and a *.</p> <p><b>Example of a simple dial plan used in a Home/Office in the US:</b></p>

	<p>{^1900x.   &lt;=1617&gt;[2-9]xxxxxx   1[2-9]xx[2-9]xxxxxx   011[2-9]x.   [3469]11 }</p> <p>Explanation of example rule (reading from left to right):</p> <ul style="list-style-type: none"> <li>• ^1900x. – prevents dialing any number started with 1900</li> <li>• &lt;=1617&gt;[2-9]xxxxxx – allow dialing to local area code (617) numbers by dialing 7 numbers and 1617 area code will be added automatically</li> <li>• 1[2-9]xx[2-9]xxxxxx  - allow dialing to any US/Canada Number with 11 digits length</li> <li>• 011[2-9]x. – allow international calls starting with 011</li> <li>• [3469]11 – allow dialing special and emergency numbers 311, 411, 611 and 911</li> </ul> <p><b>Note:</b> In some cases, where the user wishes to dial strings such as *123 to activate voice mail or other applications provided by their service provider, the * should be predefined inside the dial plan feature. An example dial plan will be: {*x+} which allows the user to dial * followed by any length of numbers.</p>
<b>Ringtone</b>	
<b>Account Ringtone</b>	Configures ringtone for the account. <i>Default is "System Ringtone"</i>
<b>Ignore Alert-Info header</b>	Configures to play default ringtone by ignoring Alert-Info header. <i>Default is "Disabled"</i>
<b>Match Incoming Caller ID</b>	Specifies matching rules with number, pattern or Alert Info text to ring the selected ringtone. There are up to 10 Matching Rules.

*Accounts – Call Settings page*

## Accounts/Advanced Settings

<b>Security Settings</b>	
<b>Check Domain Certificates</b>	Sets the device to check the domain certificates if TLS/TCP is used for SIP Transport. <i>The default setting is "No".</i>
<b>Validate Certification Chain</b>	Configures whether to validate certification chain, when TLS/TCP is configured for SIP Transport. If this is set to "Yes", phone will validate server against the new certificate list. <i>The default setting is "No".</i>
<b>Validate Incoming SIP Messages</b>	Specifies if the device will check the incoming SIP messages caller ID and CSeq headers. If the message does not include the headers, it will be rejected. <i>The default setting is "No".</i>
<b>Allow Unsolicited REFER</b>	It is used to configure whether to dial the number carried by Refer-to after receiving SIP REFER request actively. If it is set to "Disabled", the device will send error warning and stop dialing. If it is set to "Enabled/Force Auth", the device will dial the number after sending authentication, if the authentication failed, then the dialing will be stopped. If it is set to "Enabled", the device will dial up all numbers carried by SIP REFER. <i>The default is "Disabled".</i>
<b>Accept Incoming SIP from Proxy Only</b>	When set to "Yes", the SIP address of the Request URL in the incoming SIP message will be checked. If it doesn't match the SIP server address of the account, the call will be rejected
<b>Check SIP User ID for Incoming INVITE</b>	Configures the device to check the SIP User ID in the Request URI of the SIP INVITE message from the remote party. If it doesn't match the device's SIP User ID, the call will be rejected. <i>The default setting is "No".</i>
<b>Allow SIP Reset</b>	It is used to configure whether to allow SIP Notification message to perform factory reset on the device. <i>The default setting is "No".</i>

<b>Authenticate Incoming INVITE</b>	Configures the device to authenticate the SIP INVITE message from the remote party. If set to “Yes”, the device will challenge the incoming INVITE for authentication with SIP 401 Unauthorized response. <i>Default is “No”.</i>
<b>SIP Realm used for Challenge INVITE &amp; NOTIFY</b>	Configure this item to validate incoming INVITE, but you must enable authenticate incoming INVITE first to make it take effect. You can verify the NOTIFY information for the provision, including check-sync, resync and reboot, but only when SIP NOTIFY authentication enabled first to make it take effect.
<b>MOH</b>	
<b>MOH Mode</b>	Configures MOH mode. If set to “Local MOH”, a local MOH audio file needs to be uploaded for this mode to work. <i>Default is “Disabled”</i>
<b>Upload Local MOH Audio File</b>	Upload Local MOH Audio File. Click to upload audio file from PC. <i>Note: The MOH audio file should be “.ogg” format</i>
<b>Advanced Features</b>	
<b>Special Feature</b>	Different soft switch vendors have special requirements. Therefore, users may need to select special features to meet these requirements. Users can choose from Standard, Nortel MCS, BroadSoft, CBCOM, RNK, Sylantro, Huawei IMS, Phonepower, UCM Call center, or Zoom.
<b>Allow Sync Phonebook Via SIP Notify</b>	Allow Sync Phonebook Via SIP Notify If set to “Yes”, the phone will allow SIP NOTIFY messages to sync local phonebook. <i>Default is “Enabled”</i>

*Accounts – Advanced Settings page*

## Account Swap

Swap a SIP Account with another one, from 1 to 16, then click on “Start”.

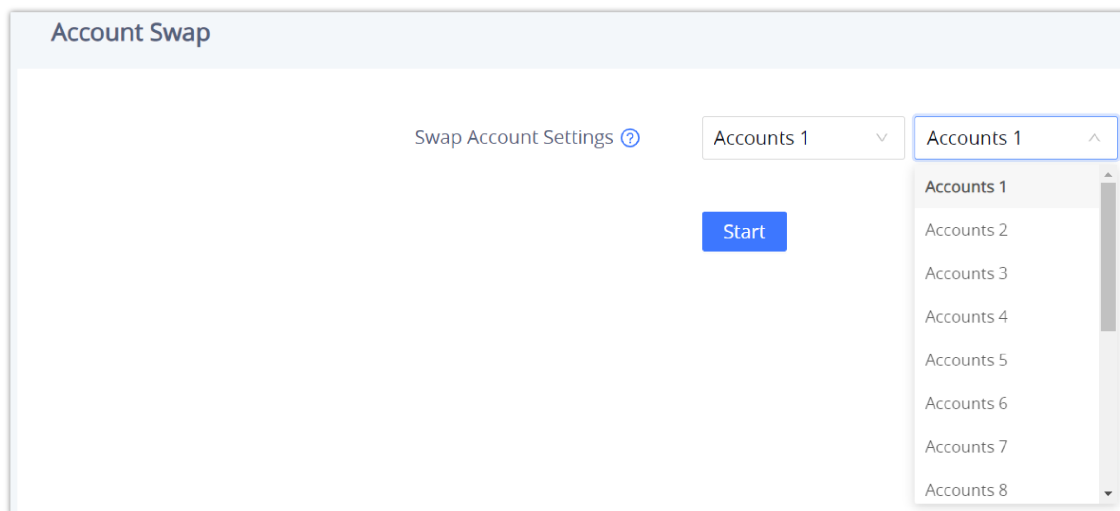

*Account Swap*

## Calls Page Definition

### Outgoing Calls

The GSC35x6 (V2) allows users to manage their calls using the Click to Dial feature which permits to initiate and receive calls using the Web GUI. To use the Click to Dial feature, please refer the following steps:

1. Go under the GSC35x6 (V2) **Web GUI** → **Calls** → **Outgoing Calls**



2. Select the account to be used.

3. Type the number / IP Address to call and press the **Dial** button  as displayed in the following screenshots:



*Click-to-Dial Feature*

Once the number / IP address is dialed or a Call is received, a window pops up showing the call information and gives the user the ability to do the following operations:

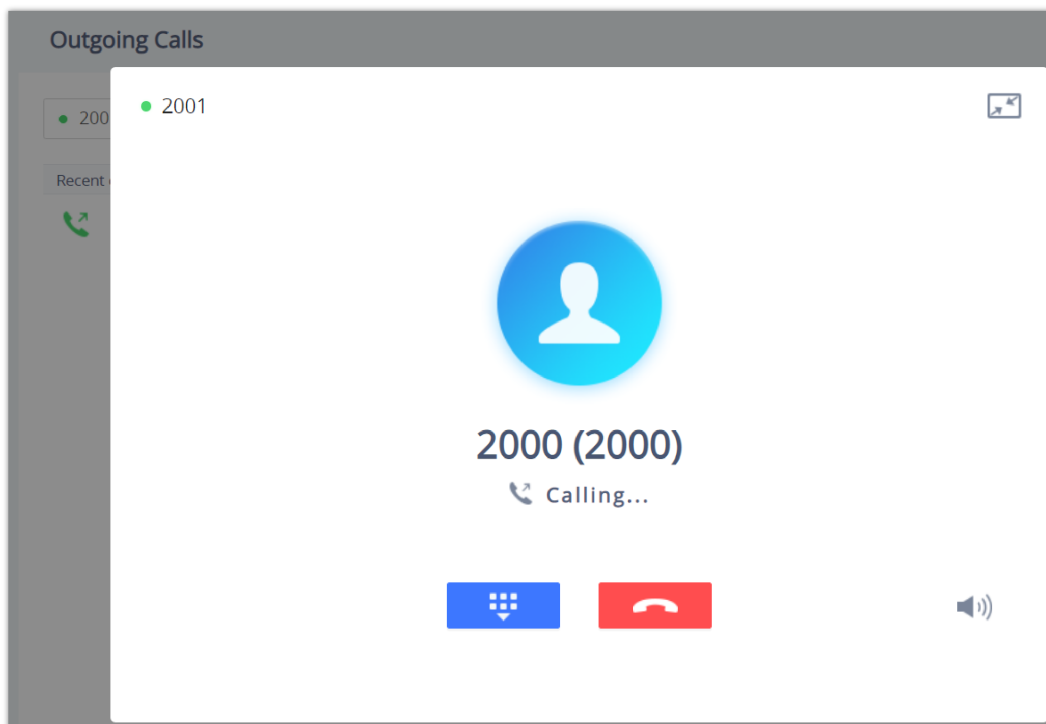

*Outgoing Call – Calling*

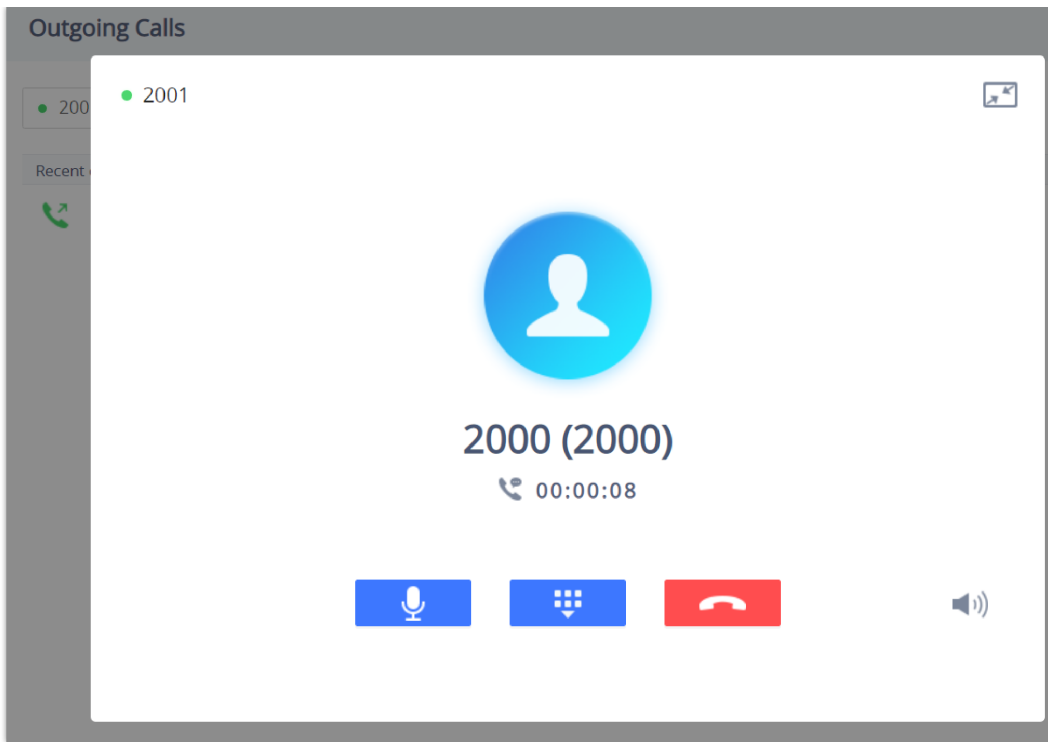

Outgoing call in progress and accepted

 : Reduce the window to a bar at the top of the Web GUI interface.

 : Adjust the ringing volume.

 : Mute the Mic.

 : Start recording the call.

 : End the in-progress call.

## Call History







The GSC35x6 (V2) Call History is divided into two sections: "Call history" and "Intercepted Record":

### Call history

This section shows all the calls that have been made or answered. Users can find two types of calls under "Call History → Call history":

 Outgoing Calls.

 Answered Calls.

Call History				
Call history		Intercept record		
<input type="checkbox"/>	Delete	Delete all	Add to whitelist	Add to blacklist
<input type="checkbox"/>	Name	Number	Time	
<input type="checkbox"/>	 2000(1)	2000	03:52:00 pm	 
<input type="checkbox"/>	 3000(1)	3000	03:51:41 pm	 



Call History → Call history

By Tapping on the checkbox to select the call history entries, users can do the following operations:

- **Delete Call History:** Users need to press the button  Delete after selecting the call history entries.

- **Add entries to Whitelist:** Users may select the entries to be allowed to call the GSC35x6 (V2) by clicking on the button [Add to whitelist](#) after selecting the right entries.
- **Add entries to Blacklist:** Users can block the calls of some entries by selecting them and pressing the button [Add to blacklist](#) .

The following operations can be done as well:

- **Make a call to one of the call history entries:** Users can directly make a call to a number listed in the call history by clicking directly on the button 
- **Show calls details:** users can show the call details of a number by clicking on the button  and a window will pop up to show all the calls sent/received with the selected number.

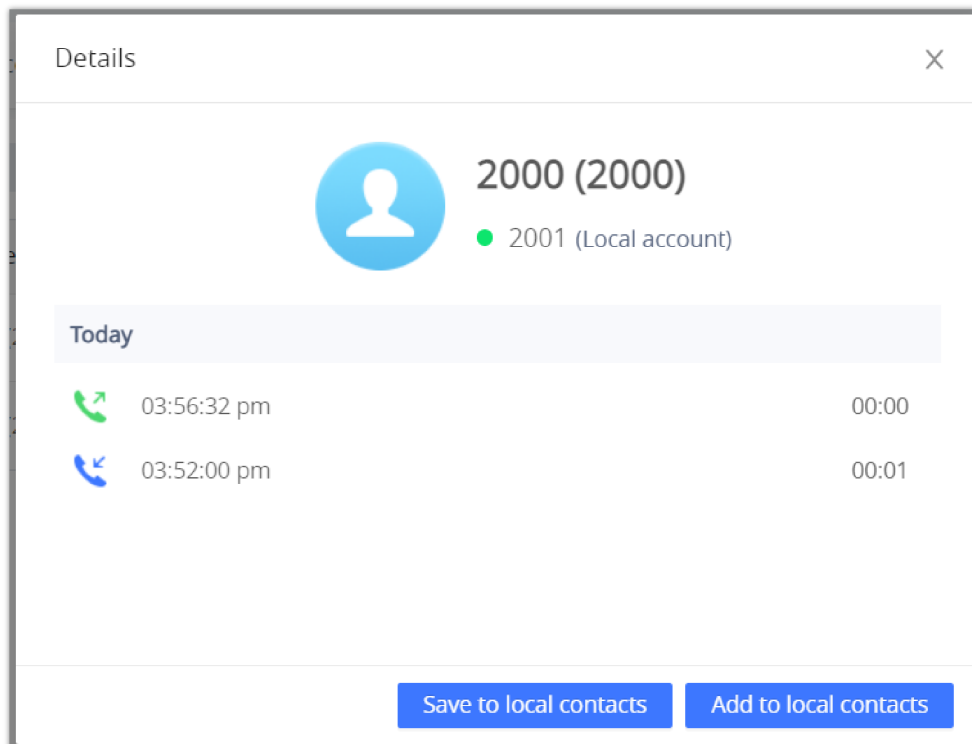

*Call details under Call History → Call history*

From the Call details window, users can also add the number selected to local contacts by creating a new contact [Add to local contacts](#) , or by adding it to an existing contact [Save to local contacts](#) .

- **Add number to an existing contact:** Users can click on “Save to local contacts” in order to show a window with all the contacts already registered in the GSC3516 local contacts and to choose one of the contacts to link the selected number with:

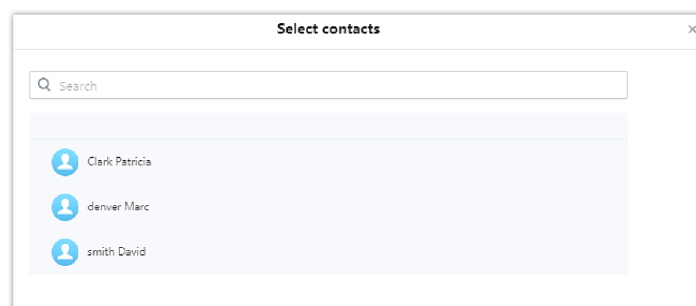

*Add number from call history to an existing contact*

- **Create a new contact:** user can click on “Add to local contacts” in order to show a window where all the information about the contact needs to be entered.

#### Note

Please, refer to the next section “Contacts” for more information about creating a new contact or editing an existing one.

## Call History → Intercept Record

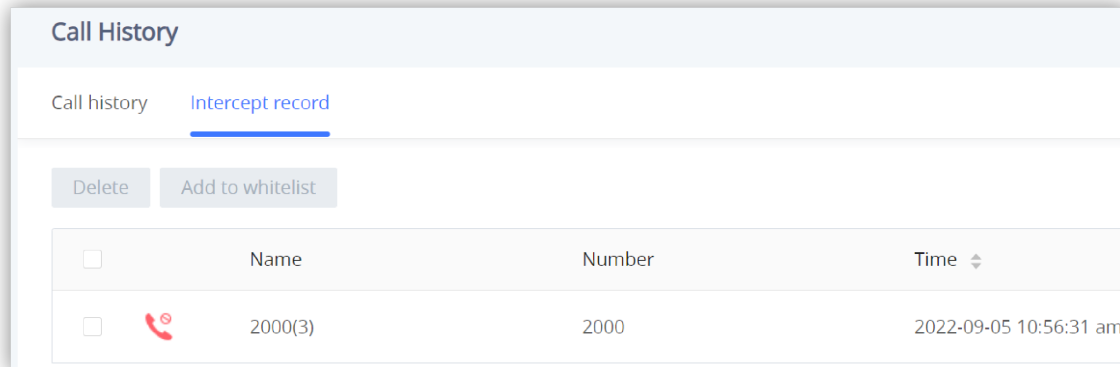

This section shows all the calls that have been blocked when received because of not having permission to make a call to the GSC3516. Users can find only one type of call under "Call History → Intercept Record":

### Blocked Calls





Call History → Intercept Record

By checking the checkbox to select entries, users can do the following operations:

- **Delete Blocked Numbers Call History:** Users need to press the button  **Delete** after selecting the call history entries.
- **Add entries to Whitelist:** Users may select the blocked entries to give them permission to call the GSC3516 by clicking on the button  **Add to whitelist** after selecting the right entries.

The following operations can be done as well:

- **Make a call to one of the entries:** Users can directly make a call to a number listed in call history → Intercept Record, by clicking directly on the button .
- **Show calls details:** users can show the call details of a number by clicking on the button  and a window will pop up to show all the blocked calls received from the selected number.

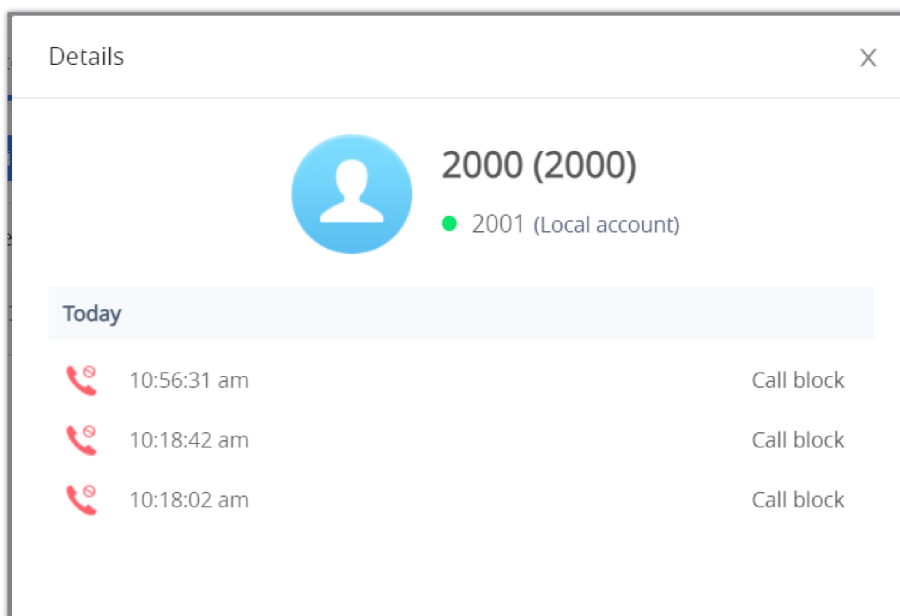

Call details under Call History → Intercept Record

## Web GUI Missed Call Notification support

The GSC GUI will display a popup window to notify about missed calls. The figure below contains an example where Extension 4444 couldn't reach the GSC at 3333.

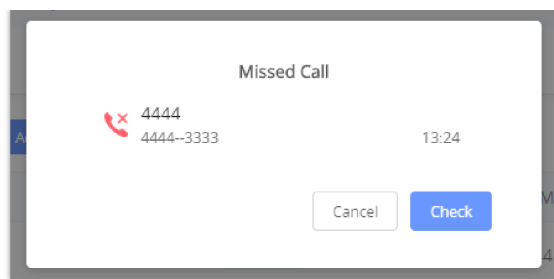

Web GUI Missed Call Notification

## Contacts

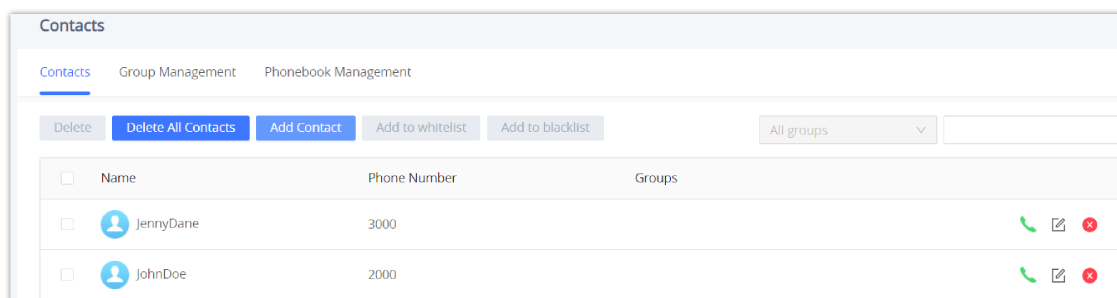

Contacts → Contacts

- Dial Contact.
- Edit contact details.
- **Delete**: Users can select one or a bunch of contacts and click on the “Delete” button in order to delete all the selected contacts.
- **Add to whitelist**: Users can select one or a bunch of contacts and click on the “Add to Whitelist” button in order to directly add the selected contacts to the list of contacts allowed to call the device.
- **Add to blacklist**: Users can select one or a bunch of contacts and click on the “Add to blacklist” button in order to remove the permission to call from the selected contacts.
- **Add Contact**: Users can create a new contact by clicking on the “Add Contact” button, then a window pops up (Please, refer to the following figure) in order to enter the new contact’s details.

Add Contact
✕

First Name

Last Name

Accounts Auto ▼

Work Number

Home Number

Mobile Number

Groups

Ringtone Auto ▼

Cancel Save

Add New Contact

## Group Management

Users could manage the groups of the existing contacts that can be found in "Contacts".



Contacts → Group Management

Users have the ability to:

- : Users can click on the "Delete" button in order to delete all the selected groups.
- **Add Group**: Users can create a new group by clicking on the "Add Group" button.

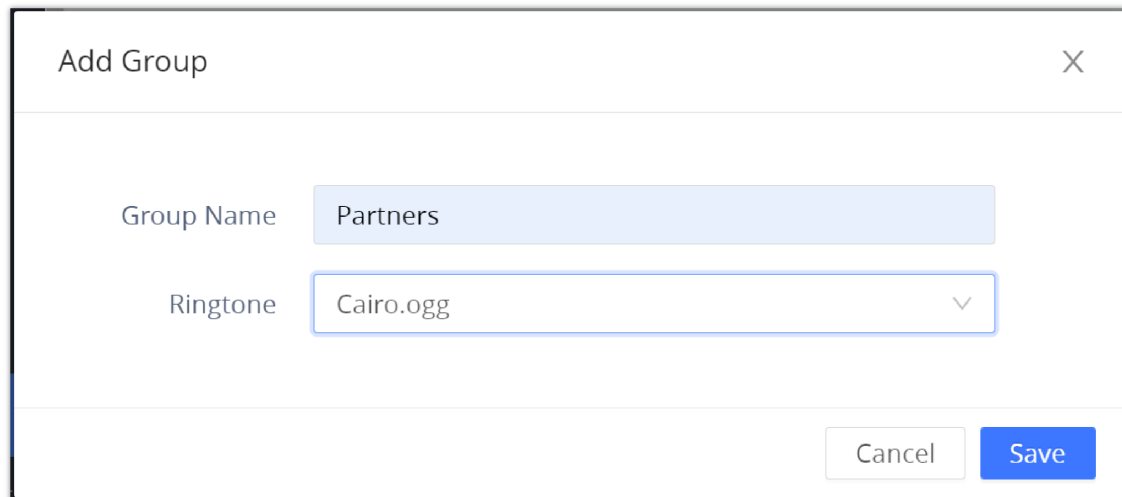

Add New Group

## Phonebook Management

<b>Enable Phonebook XML Download</b>	Enables Phonebook XML download via HTTP, HTTPS, or TFTP. <i>Default is "Disabled"</i>
<b>HTTP/HTTPS Username</b>	Enter The username for the HTTP/HTTPS server.
<b>HTTP/HTTPS Password</b>	Enter The password for the HTTP/HTTPS server.
<b>Phonebook XML Server Path</b>	Configures the server path to download XML phonebook file. This field could be IP address or URL, with up to 256 characters.
<b>Phonebook Download Interval</b>	Configures the phonebook download interval (in minutes). If set to 0, automatic download will be disabled. Valid range is 5 to 720.
<b>Clear Old List When Downloading</b>	<ul style="list-style-type: none"> <li>● If set to "Clear all", the phone will delete all previous records before downloading the new records.</li> <li>● If set to "Keep Local Contacts", manually added local contacts will not be deleted when downloading new records.</li> </ul> <p><i>Default is "No"</i></p>

<b>Replace Duplicate Items When Downloading</b>	<ul style="list-style-type: none"> <li>● If set to "Replace by name", records of the same name will be replaced automatically when downloading new records.</li> <li>● If set to "Replace by number", records of the same number will be replaced automatically when downloading new records.</li> </ul> <p><i>Default is "No"</i></p>
<b>Import Group Method</b>	<ul style="list-style-type: none"> <li>● When set to "Replace", the existing groups will be completely replaced by imported one.</li> <li>● When set to "Append", the imported groups will be appended to the current one.</li> </ul> <p>Default is "No"</p>
<b>Sort Phonebook by</b>	<p>Configures to sort phonebook based on the selection of first name, last name or auto:</p> <ul style="list-style-type: none"> <li>● If you select "Last name", the contact's last name will be displayed first, and the phone book will be sorted by last name</li> <li>● if you select "First name", the contact's first name will be displayed first, and the phone book will be sorted by first name</li> <li>● If you select "Auto", the contact will be displayed based on whether the contact contains Chinese, Japanese, and Korean characters. If there are these characters, the contact's last name will be displayed first.</li> </ul>
<b>Download XML Phonebook</b>	Click to download the XML Phonebook file
<b>Upload XML Phonebook</b>	Upload XML Phonebook file to the phone.
<b>Default Search Mode</b>	<p>Configures the default phonebook search mode:</p> <ul style="list-style-type: none"> <li>● Quick Match</li> <li>● Exact Match</li> </ul> <p><i>Default is "Quick Match"</i></p>

*Contacts – Phonebook Management page*

## Blacklist/Whitelist/Greylist Settings

This section is for managing calling permissions to the GSC35x6 (V2). Users can give or remove permission to call the GSC35x6 (V2), this can be managed under the following three subsections:

### Whitelist

Users can specify the numbers allowed to call the GSC35x6 (V2) and every time a number is added it is listed in the below list:

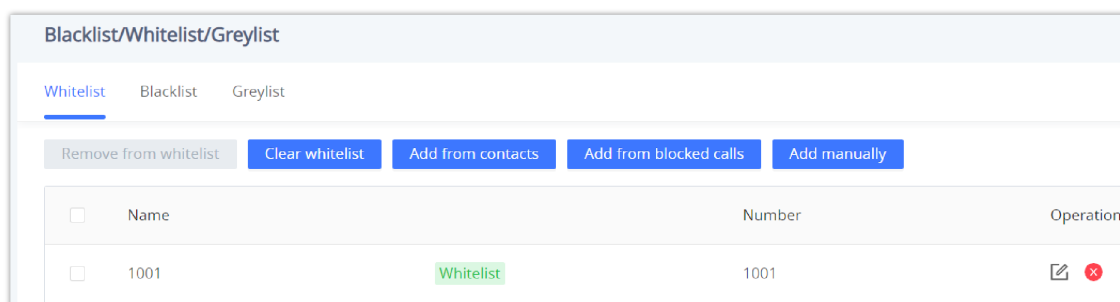

*Whitelist section*

- **Remove from whitelist**: Users can remove one or a group of numbers from the whitelist by clicking on the "Remove from Whitelist" button.  
Note: Users can also press on  to remove one specific contact from the whitelist.
- **Add from contacts**: Users can add the phonebook contacts to the whitelist by clicking on the "Add from contacts" button. A window pops up showing the existing contacts so that users can select the ones wishing to give permission.

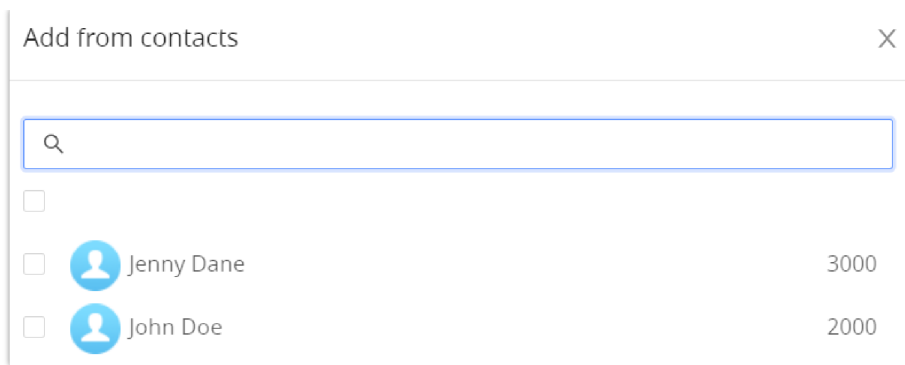

*Add phonebook contacts to the whitelist*

- **Add from blocked calls** : Users can add the numbers that the GSC35x6 (V2) is blocking to the Whitelist by clicking on "Add from blocked calls". A window pops up showing all the blocked numbers.



*Add blocked numbers to the whitelist*

- **Add manually** : Users can add numbers manually to the whitelist by clicking on the "Add manually" button. A window pops up allowing users to enter the number and its name.

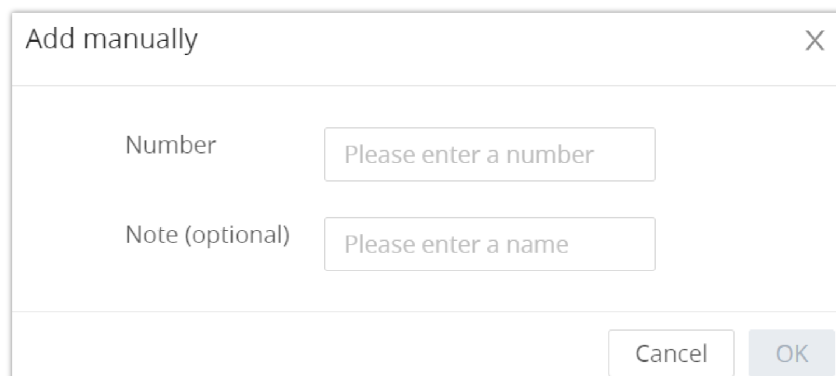

*Add Manually to Whitelist*

**Note**

Users can modify the name of the number listed in the Whitelist by clicking on .

**Blacklist**

Users can specify the numbers to be blocked by the GSC35x6 (V2) for incoming calls, and every time a number is added to the blacklist, it is listed in the below list:



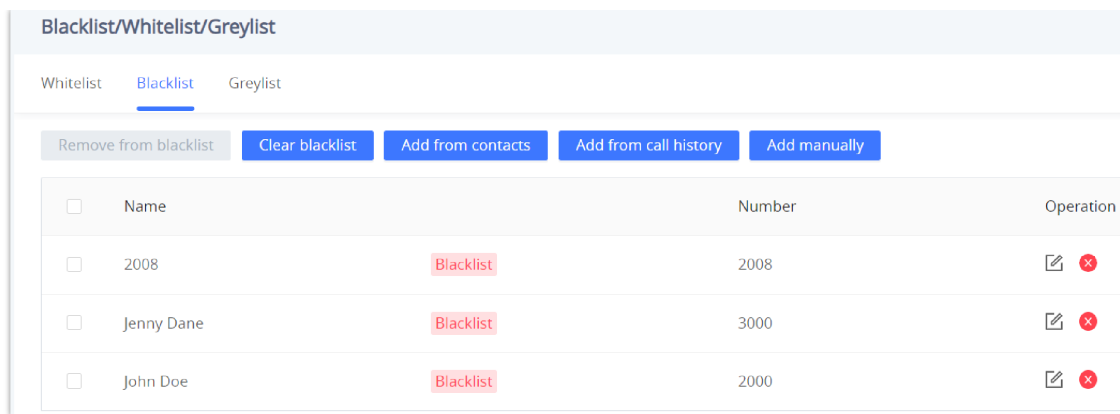

*Blacklist Section*

- **Remove from blacklist**: Users can remove one or a group of numbers from the blacklist by clicking on the "Remove from blacklist" button.

**Note:** Users can also press on  to remove one specific contact from the blacklist.

- **Add from contacts**: Users can add phonebook contacts to the blacklist by clicking on the "Add from contacts" button. A window pops up showing the existing contacts so that users may select the ones wishing to give permission to
- **Add from call history**: Users can add numbers from Call History to the blacklist by clicking on the "Add from call history" button. A window pops up showing all the calls listed in the GSC35x6 (V2) call history.



*Add from Call History to Blacklist*

- **Add manually**: Users can add numbers manually to the blacklist by clicking on the "Add manually" button.

**Note**

Users can modify the name of the number listed in the blacklist by clicking on .

## Greylist

This section allows the user to define the blocking rules for Non-white list calls. The blocking rules available for the users are:

- **Block**: Configures the GSC35x6 (V2) to block all the numbers that are not listed in the Whitelist.
- **Auto Answer**: Configures the GSC35x6 (V2) to allow all the calls received from any number but the number listed in the blacklist.
- **Set Password**: requires a password before it can be answered.
- **Ringng**: all greylist calls will continue ringing. The default ring time is 60 s.

## Phone Settings Page Definitions

### Phone Settings/General Settings

<b>Local RTP Port</b>	Defines the local RTP port pair used to listen and transmit. <i>The default value is 5004. The valid range is from 1024 to 65400.</i>
<b>Local RTP Port Range</b>	Configures the range of local RTP port. Valid value is from 24 to 10000. <i>Default is "200"</i>
<b>Use Random Port</b>	Forces the device to use random ports for both SIP and RTP messages. This is usually necessary when multiple phones are behind the same full cone NAT. <i>The default setting is "No".</i> <b>Note:</b> <i>This parameter must be set to "No" for Direct IP Calling to work.</i>
<b>Keep-alive Interval</b>	Specifies how the device will send a Binding Request packet to the SIP server in order to keep the "ping hole" on the NAT router to open. <i>The default setting is 20 seconds. The valid range is from 10 to 160.</i>
<b>STUN Server</b>	Configures the URI of STUN (Simple Traversal of UDP for NAT) server. The device will send STUN Binding Request packet to the STUN server to learn the public IP address of its network. Only non-symmetric NAT routers work with STUN.
<b>TURN Server Username</b>	Fill in the username to validate TURN server.
<b>TURN Server Password</b>	Fill in the password to validate TURN server.
<b>Use NAT IP</b>	Configures the IP address for the Contact header and Connection Information in the SIP/SDP message. It should ONLY be used if it's required by your ITSP. <i>By default, the box is blank.</i>

### Phone Settings – General Settings

## Call Settings

<b>Enable Call Waiting</b>	Enables call waiting feature. If it is disabled, it will reject the second incoming call during an active session without user's knowledge. But this missed call record will be saved to remind users. <i>The default setting is checked (enabled).</i>
<b>Enable Call Waiting Tone</b>	Sets to play the call waiting tone along with LED indicator if there is another incoming call. If unchecked, only LED will indicate another incoming call. <i>The default setting is checked (enabled).</i>
<b>End-Call Tone</b>	If enabled, there will be a prompt tone when the call ends. Disabled by Default
<b>Multicast Tone</b>	If enabled, there will be a prompt tone at the beginning and end of the multicast. Disabled by Default
<b>Automatic Answer Ringing Time (s)</b>	Configures the ring time for the unanswered call. The call will be automatically answered after timeout. <i>Default is 0.</i>
<b>Busy Tone Ring Time (s)</b>	Configures the timeout for Busy Tone during the call. <i>Default is 30.</i>
<b>Auto Mute Mode</b>	Configures whether to mute the call on entry automatically. <ul style="list-style-type: none"> <li>• If set to "Disable", then do not use auto mute function.</li> <li>• If set to "Auto Mute on Outgoing Call", then mute automatically when the other party answers the outgoing call.</li> <li>• If set to "Auto Mute on Incoming Call", then mute automatically when answers the incoming call</li> <li>• If set to "Mute on Incoming &amp; Outgoing Call", then mute automatically when the call gets through.</li> </ul>

	<i>Note: This function only take effect when the device is from the idle status to call status. Users could click the Mute button on call interface to cancel the current mute status.</i>
<b>Filter Characters</b>	Sets the characters for filter when dial out numbers. Users could set up multiple characters. For example, if set to “[()-]”, when dial (0571)-8800-8888, the character “()-“ will be automatically filtered and dial 057188008888 directly
<b>Do Not Escape ‘#’ as %23 in SIP URI</b>	Replaces # by %23 for some special situations.
<b>Record Mode</b>	Configures phone recording mode <ul style="list-style-type: none"> <li>• If set to “Record locally”, then will use the local tape recorder for call recording, and the audio file will be saved in accordance with the tape recorder setup</li> <li>• If set to “Record on PortaOne”, then will send the specified SIP messages to the corresponding server;</li> <li>• If set to “Record on UCM”, then will send the recording feature code to the UCM server to request for recording, and the recording function will be executed by the server.</li> </ul>
<b>Environment</b>	Sets operating environment for the device. <ul style="list-style-type: none"> <li>• When set to “Small and medium size room &amp; used on desk”, the sound pickup range is increased and ENC is reduced</li> <li>• When set to “Large room &amp; used on empty area”, the sound pickup range is reduced and ENC is increased.</li> </ul> <p><i>The default value is “Large room &amp; used on empty area”.</i></p>

*Phone Settings – Call Settings*

## Ringtone

<b>Auto Config CPT by Region</b>	Configures whether to choose Call Progress Tone automatically by region. If set to “Yes”, the device will configure CPT (Call Progress Tone) according to different regions automatically. If set to “No”, you can manual configure CPT parameters. <i>The default setting is “No”.</i>
<ul style="list-style-type: none"> <li>• Ring Back Tone</li> <li>• Busy Tone</li> <li>• Reorder Tone</li> <li>• Call-Waiting Tone</li> </ul>	<p>Configures tone frequencies according to user preference. By default, the tones are set to North American frequencies. Frequencies should be configured with known values to avoid uncomfortable high pitch sounds.</p> <ul style="list-style-type: none"> <li>• Syntax: f1=val,f2=val [,c=on1/off1[-on2/off2[-on3/off3]]];</li> </ul> <p>(Frequencies are in Hz and cadence on and off are in 10ms)</p> <p>ON is the period of ringing (“On time” in “ms”) while OFF is the period of silence. In order to set a continuous ring, OFF should be zero. Otherwise it will ring ON ms and a pause of OFF ms and then repeats the pattern.</p> <p><i>Please refer to the document below to determine your local call progress tones: <a href="http://www.itu.int/ITU-T/inr/forms/files/tones-0203.pdf">http://www.itu.int/ITU-T/inr/forms/files/tones-0203.pdf</a></i></p>
<b>Call-Waiting Tone Gain</b>	Adjusts the call waiting tone volume. Users can select “Low”, “Medium” or “High”. <i>The default setting is “Low”.</i>
<b>Default Ring Cadence</b>	Defines the ring cadence for the device. <i>The default setting is: c=2000/4000.</i>

*Phone Settings – Ringtone*

## Multicast/Group Paging

<b>Multicast Paging</b>
-------------------------

<b>Paging Barge</b>	Sets the threshold of paging calls. If the paging call's priority is higher than the threshold, the existing call will be hold and the paging call will be answered. Otherwise, the existing call does not be affected. If it is set to Disable (Default), any paging call will not be answered.
<b>Paging Priority Active</b>	Determines if a new paging call whose priority is higher than the existing paging call will be answered. <i>The default is disabled. Check to enabled.</i>
<b>Multicast Listening</b>	
<b>Priority</b>	Configures the IP address and port number for monitoring multicast paging call. Reboot the device to make changes take effect.
<b>Listening Address</b>	The valid IP address range is from 224.0.0.0 to 239.255.255.255.
<b>Label</b>	Label for each listening address corresponding to priority.
<b>Push-to-Talk/Group Paging</b>	
<b>General Settings</b>	
<b>Group Paging Address</b>	Allows to configure the group paging IP address.
<b>IGMP Keep-alive Interval (s)</b>	Specifies how often the phone reports IGMP when Group Paging function is turned on. IGMP report helps to keep Group Paging alive in sleep state.
<b>Emergency Group Paging Volume</b>	Configures default volume for group paging when emergency channel/group is used.
<b>Push-to-Talk Config</b>	
<b>Push-to-Talk</b>	Configures to enable or disable Push-to-Talk. <i>Default is "Disabled"</i>
<b>Priority Channel</b>	Set priority channel for Push-to-Talk. Push-to-Talk received on priority channel will take precedence over active Push-to-Talk on normal channel. <i>Priorities go from 1 to 25.</i>
<b>Emergency Channel</b>	Set emergency channel for Push-to-Talk. Emergency channel has the highest priority. Push-to-Talk using emergency channel will take precedence over Push-to-Talk on priority or normal channel. Please note Push-to-Talk to emergency channel will not be rejected even when device has enabled DND.
<b>Accept While Busy</b>	Configures whether to accept Push-to-Talk while device is in active call. If set to "No", device will ignore Push-to-Talk while in active call. If set to "Yes", while in active Push-to-Talk talk, device will accept Push-to-Talk if it has the same priority; If device is in active SIP call, device will accept Push-to-Talk and put the SIP call on hold. <i>Default is "Disabled"</i>
<b>Channel</b>	Configures Push-to-Talk channel. Configures options for the channel such as transport, accept, join Push-to-Talk and its label. Only available and joined channel will be displayed in Push-to-Talk channel list. If users need send or receive Push-to-Talk, "Transport" and "Accept" must be enabled for this channel.
<b>Paging Config</b>	
<b>Group Paging</b>	Allows to enable or disable group paging.
<b>Priority Group</b>	Configures priority paging group. Paging received on priority group will take precedence over active paging on normal group.

<b>Emergency Group</b>	Set emergency group for paging. Emergency group has the highest priority. Paging using emergency group will take precedence over paging on priority or normal group.
<b>Accept While Busy</b>	Configures whether to accept paging while device is in active call. If set to “No”, device will ignore paging while in active call. If set to “Yes”, while in active paging call, the device will accept other paging calls if it has the same priority. If device is in an active SIP call, device will accept paging and hang up the SIP call.
<b>Group</b>	Configures paging group. Users can configure whether to use the group to accept and join group, and its label. Only available and joined group will be displayed in paging group list. If users need receive paging, “Subscribe” must be enabled for this group.

*Multicast/Group Paging*

## Network Settings Page Definitions

### Ethernet Settings

<b>Internet Protocol</b>	If IPv4 is selected, the device will be using IPv4 addressing, otherwise, it will be using IPv6 addressing.  The default is Prefer IPv4.
<b>Different Networks for Data and VoIP Calls</b>	Configures whether to set up different networks for the phone data and the call. If set to “Yes”, you need to configure the data network and VoIP network respectively.  <b>Note:</b> Reboot is required to take effect.
<b>IPv4</b>	
<b>IPv4 Address Type</b>	Allows users to configure the appropriate network settings on the device. Users could select “DHCP”, “Static IP” or “PPPoE”.  <ul style="list-style-type: none"> <li>○ <b>DHCP:</b> Obtain the IP address via one DHCP server in the LAN. All domain values about static IP/PPPoE are unavailable (although some domain values have been saved in the flash.)</li> <li>○ <b>PPPoE:</b> Configures PPPoE account/password. Obtain the IP address from the PPPoE server via dialing. (When “Different Networks for Data and VoIP Calls” is set to Yes; it will be available for “Network Configuration of Data” only).</li> <li>○ <b>Static IP:</b> Manually configures IP Address, Subnet Mask, Default Router’s IP Address, DNS Server 1, and DNS Server 2.</li> </ul> <p>By default, it is set to “DHCP”.</p>
<b>DHCP VLAN Override</b>	DHCP Option 132 defines VLAN ID and DHCP Option 133 defines priority tag ID.  it supports DHCP VLAN override via DHCP Option 132 and DHCP Option 133, or encapsulated DHCP option 132 and DHCP option 133 in DHCP option 43.  <ul style="list-style-type: none"> <li>○ Users could select “<b>Disable</b>”, “DHCP Option 132 and DHCP Option 133”, or “Encapsulated in DHCP Option 43”.</li> <li>○ When set to “<b>DHCP Option 132 and DHCP Option 133</b>”, the device will get DHCP Option 132 as VLAN ID and get DHCP Option 133 as VLAN priority, from the DHCP server directly.</li> <li>○ When set to “<b>Encapsulated in DHCP Option 43</b>”, the device will get VLAN ID and VLAN priority value from the DHCP Option 43 which has DHCP Option 132 and DHCP Option 133 encapsulated. In this case, please make sure the option “Allow DHCP Option 43 and Option 66 to Override Server” is enabled under web UI → <b>Maintenance</b> → <b>Upgrade</b>.</li> </ul> <p>By default, it is set to “Disabled”</p>

<b>Host name (Option 12)</b>	Sets the name of the client in the DHCP request. It is optional but may be required by some Internet Service Providers.
<b>Vendor Class ID (Option 60)</b>	Configures the vendor class ID header in the DHCP request.  Default setting is "Grandstream GSC3516" or "Grandstream GSC3516".
<b>DNS Server 1</b>	Configures the primary DNS IP address.
<b>DNS Server 2</b>	Configures the secondary DNS IP address.
<b>Preferred DNS Server</b>	Configures the Preferred DNS Server.
<b>Layer 2 QoS 802.1Q/VLAN Tag (Ethernet)</b>	Assigns the VLAN Tag of the Layer 2 QoS packets for Ethernet.  The Default value is 0.  <ul style="list-style-type: none"> <li>○ <b>for Data</b>      <b>Note:</b> When "Different Networks for Data and VoIP Calls" is set to Yes, user needs to set "Layer 2 QoS 802.1Q/VLAN Tag (Ethernet) for Data" and "Layer 2 QoS 802.1Q/VLAN Tag (Ethernet) for VoIP Calls".</li> <li>○ <b>for VoIP Calls</b></li> </ul>
<b>Layer 2 QoS 802.1p Priority Value (Ethernet)</b>	Assigns the priority value of the Layer 2 QoS packets for Ethernet.  The Default value is 0.  <ul style="list-style-type: none"> <li>○ <b>for Data</b>      <b>Note:</b> When "Different Networks for Data and VoIP Calls" is set to Yes, the user needs to set "Layer 2 QoS 802.1p Priority Value (Ethernet) for Data" and "Layer 2 QoS 802.1p Priority Value (Ethernet) for VoIP Calls".</li> <li>○ <b>for VoIP Calls</b></li> </ul>
<b>IPv6</b>	
<b>IPv6 Address</b>	Configures the appropriate network settings on the device. Users could select "Auto-configured" or "Statically configured".
<b>Static IPv6 Address</b>	Enter the static IPv6 address in the "Statically configured" IPv6 address type.
<b>IPv6 Prefix Length</b>	Enter the IPv6 prefix length in the "Statically configured" IPv6 address type.
<b>IPv6 Gateway</b>	The gateway when static IPv6 is used.
<b>DNS Server 1</b>	Configures the primary DNS IP address.
<b>DNS Server 2</b>	Configures the secondary DNS IP address.
<b>Preferred DNS Server</b>	Configures the Preferred DNS Server.
<b>802.1x Mode</b>	
<b>802.1x mode</b>	Enables and selects the 802.1x mode for the device. The supported 802.1x modes are <b>EAP-MD5</b> , <b>EAP-TLS</b> , and <b>EAP-PEAP</b> . The default setting is "Disable".
<b>802.1x Identity</b>	Enters the identity information for the selected 802.1x mode. (This setting will be displayed only if 802.1 X mode is enabled).
<b>802.1x Password</b>	Enter the MD5 Password for 802.1X mode.
<b>CA Certificate</b>	Uploads the CA Certificate file to the device. (This setting will be displayed only if the 802.1 X mode is enabled)

<b>Client Certificate</b>	Loads the Client Certificate file to the device. (This setting will be displayed only if the 802.1 X TLS mode is enabled)
---------------------------	---

*Network Settings – Ethernet Settings*

## Wi-Fi Settings

**Note**

The Wi-Fi is supported only on the GSC3516 Speaker Model

### Connect to Wi-Fi Network

Users can connect wirelessly to a network using Wi-Fi under **GSC3516 Web GUI → Network Settings → Wi-Fi Settings**. In order to connect to a network using Wi-Fi, please, refer to the following steps:

- 1 – Go to **GSC3516 Web GUI → Network Settings → Wi-Fi Settings**
- 2 – Enable **Wi-Fi Function** by clicking on Enable.
- 3 – Click on **Scan** to show the list of Wi-Fi networks available around the GSC3516.

**Note**

The list of Wi-Fi Networks refreshes automatically every 15 seconds and user can force to refresh by clicking again on “Scan”.

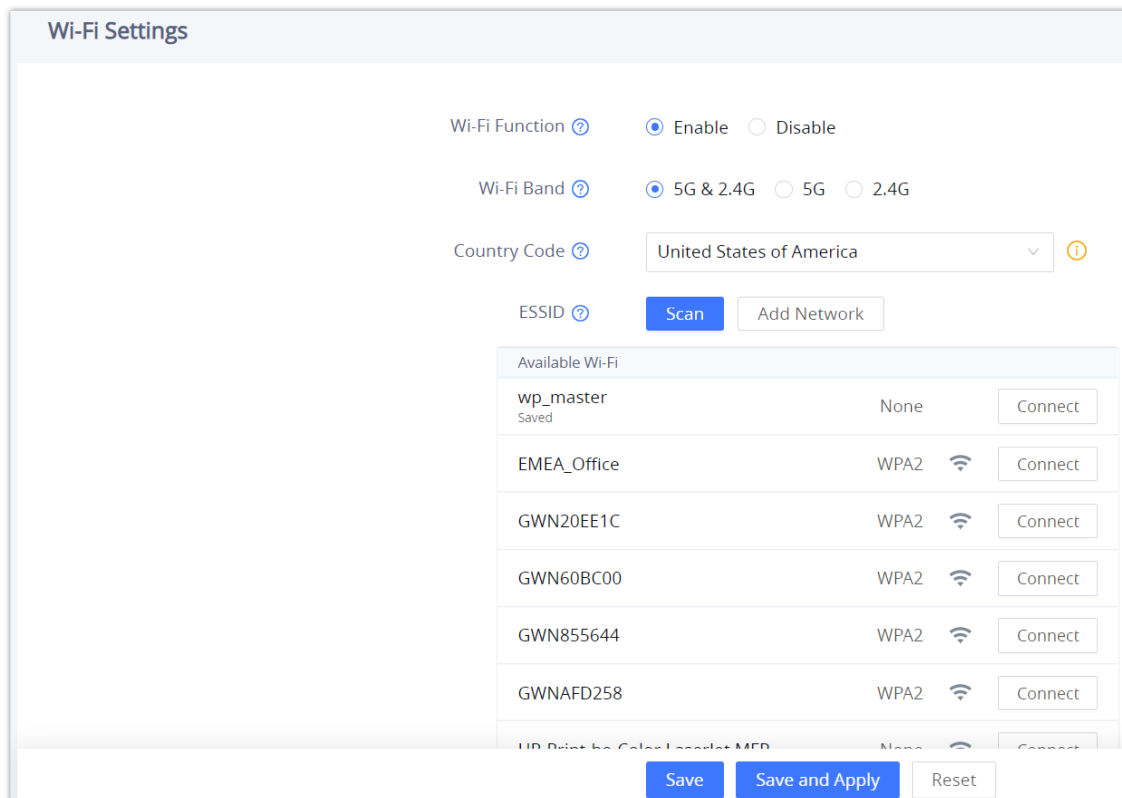

*Wi-Fi Settings Page*

- 4 – Identify the Wi-Fi network’s SSID and click on “Connect”, then enter the correct password information to connect to the selected network:

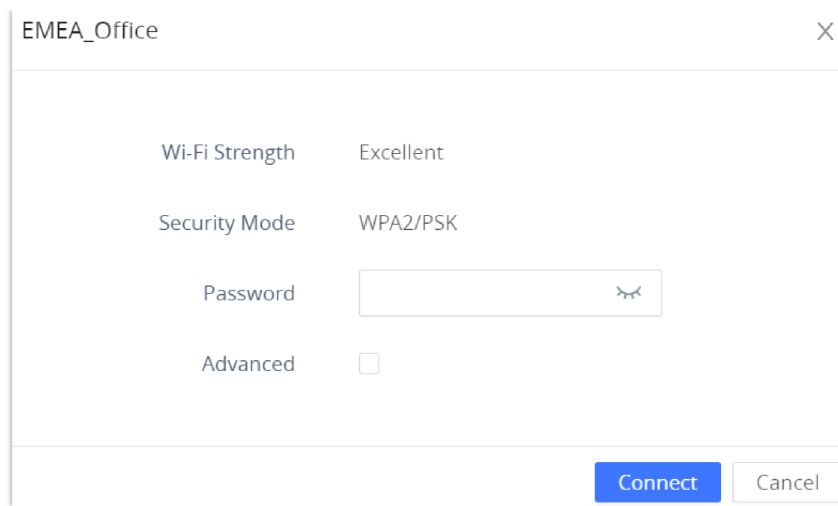

Connect to Wi-Fi Network

5. Users can check the Wi-Fi parameters and change the setting by checking the "advanced" at the bottom.

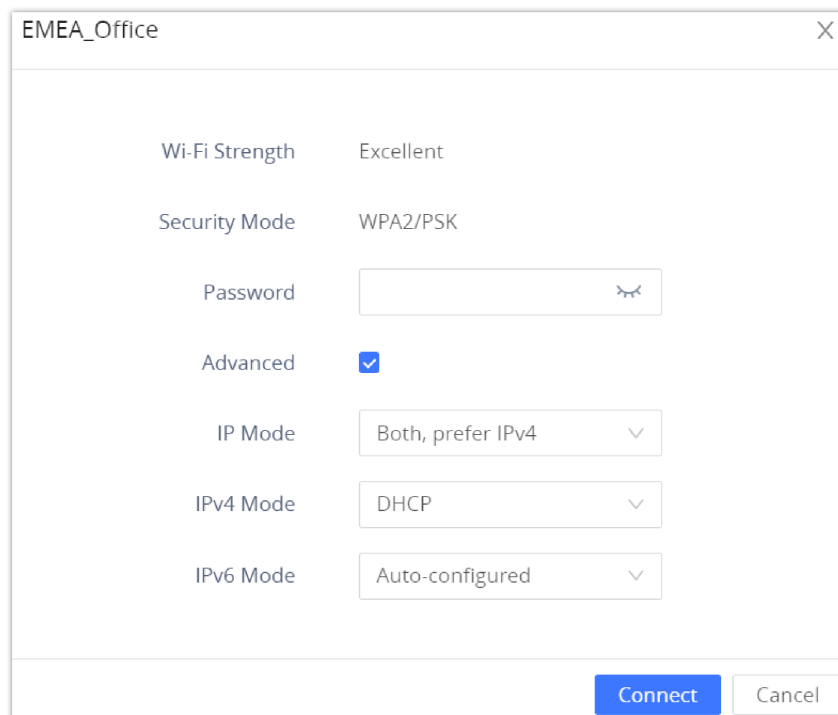

Wi-Fi – Advanced

### Wi-Fi Settings description

<b>Wi-Fi Function</b>	Enables/disables the Wi-Fi feature. The default setting is "Disable".
<b>Wi-Fi Band</b>	Configures the Wi-Fi frequency band from the dropdown list: <ul style="list-style-type: none"> <li>• 2.4G</li> <li>• 5G</li> <li>• Dual band (2.4 G &amp; 5G)</li> </ul>
<b>Country Code</b>	Configures Wi-Fi country code. The default value is "United States of America". <b>Note:</b> Reboot is requested to take effect.
<b>ESSID</b>	This parameter sets the ESSID for the Wireless network. Press "Scan" to scan for the available wireless network.
<b>Scan</b>	Allows to scan and select the available Wi-Fi networks within the range where the Wi-Fi feature is enabled. Click on "Connect" to select the Wi-Fi network and connect. The ESSID will be auto-filled in the ESSID field, users can also click on "Details" to



	have more details about the connected ESSID with its status, strength, and security mode. they can either edit the attributes of the network or forget the network.
<b>Add Network</b>	
<b>ESSID</b>	Determines the ESSID of the default Wi-Fi network.
<b>Security Mode</b>	<p>This parameter defines the security mode used for the wireless network when the SSID is hidden. 5 Modes are available:</p> <ul style="list-style-type: none"> <li>• <b>None</b></li> <li>• <b>Auto</b></li> <li>• <b>WEP</b></li> <li>• <b>WPA</b></li> <li>• <b>WPA-802.1x</b></li> </ul> <p>It is set to "None" By default.</p>
<b>Advanced</b>	<p>When this option is checked, it gives you the possibility to define the following parameters :</p> <ul style="list-style-type: none"> <li>• <b>IP Mode:</b> Configures the IP mode, it can be either IPv4 only, IPv6 only, Both with IPv4 Preference, or Both with IPv6 Preference</li> <li>• <b>IPv4 Mode:</b> Configures the IPv4 mode to be either static or using a DHCP server. in the case where it is set to static, the following parameters need to be configured: IPv4 Address, Subnet Mask, Gateway, DNS Server 1, DNS Server 2, and Preferred DNS Server.</li> <li>• <b>IPv6 Mode:</b> Configures the Ipv6 mode to be either auto-configured or statistically configured. in the case where it is set to statistically configured the following parameters need to be set: Static Mode( Full static, Prefix static), IPv6 Address, IPv6 Prefix length, DNS Server 1, DNS Server 2, Preferred DNS Server</li> </ul>
<b>Password</b>	When the following security modes are picked: Auto, WEP, WPA, and WPA-802.1x, the user must enter a specific password for the ESSID.
<b>EAP Method</b>	<p>When WPA-802.1x is selected, users can choose one of the below EAP methods which can be configured for credential-based or certificate authentication.</p> <ul style="list-style-type: none"> <li>• <b>PEAP</b></li> <li>• <b>TLS</b></li> <li>• <b>TTLS</b></li> <li>• <b>PWD</b></li> </ul>
<b>Phase 2 Authentication</b>	<p>Configures the keys to encrypt and decrypt the IPSec packets on the host, it can be set to :</p> <ul style="list-style-type: none"> <li>• <b>None</b></li> <li>• <b>MSCHAPV2</b></li> <li>• <b>GTC</b></li> </ul>
<b>CA Certificate</b>	Upload the 802.1x CA certificate to the phone, or delete existed 802.1x CA certificate from the phone.
<b>Anonymous Identity</b>	If an anonymous identity username is entered, the wi-fi connection will use a dummy, anonymous identity to establish the connection.
<b>Identity</b>	Defines the Identity information for the 802.1x mode.

## Bluetooth

### Note

The Bluetooth feature is available only on the GSC3516 Speaker Model

<b>Bluetooth</b>	Enable or Disable Bluetooth
<b>Discoverable to Nearby Bluetooth Devices</b>	Enable to be discoverable via Bluetooth by nearby devices.
<b>Visibility timeout</b>	Configures visibility timeout to nearby devices before turning back to invisible mode. The default is 2 minutes.
<b>Bluetooth PIN</b>	Set up a 6 digits PIN Code. The PIN is required when pairing other Bluetooth devices.
<b>Device Name</b>	Configures the name that will be shown to other Bluetooth devices.
<b>Paired devices</b>	Lists paired devices.  Press <input type="button" value="Unpair"/> to unpair/remove the device from the list.

*Network Settings – Bluetooth*

## OpenVPN® Settings

<b>OpenVPN® Enable</b>	Enable/Disable the OpenVPN® feature. <i>Default setting is "Disabled"</i>
<b>Manual Import</b>	
<b>Import OpenVPN® Configuration</b>	Import the configuration file from the current computer. After importing, the local configuration will be overwritten and OpenVPN® function is automatically enabled. <i>Note: Please import *.ovpn file</i>
<b>Local Configuration</b>	
<b>OpenVPN® Server Address</b>	The URL/IP address for the OpenVPN® server.
<b>OpenVPN® Port</b>	The network port for the OpenVPN® server. By default, it is set to 1194.
<b>OpenVPN® Transport</b>	Determines network protocol used for OpenVPN®: UDP or TCP.
<b>OpenVPN® CA</b>	OpenVPN® CA file (ca.crt) required by the OpenVPN® server for authentication purposes. Press "Upload" to upload the corresponding file to the device.
<b>OpenVPN® Certificate</b>	OpenVPN® Client certificate file (*.crt) required by the OpenVPN® server for authentication purposes. Press "Upload" to upload the corresponding file to the device.
<b>OpenVPN® Client Key</b>	The OpenVPN® Client key (*.key) required by the OpenVPN® server for authentication purposes. Press "Upload" to upload the corresponding file to the device.
<b>OpenVPN® TLS Key</b>	Click the button "Upload" to upload TLS key: <b>Note: .key file</b>
<b>OpenVPN® TLS Key Type</b>	Select the encryption type of the OpenVPN® TLS key.
<b>OpenVPN® Cipher Method</b>	Same cipher method must be used by the OpenVPN® server: Blowfish, AES=128, AES-256, Triple-DES
<b>OpenVPN® Username</b>	OpenVPN® authentication username (optional).

<b>OpenVPN® Password</b>	OpenVPN® authentication password (optional).
<b>OpenVPN® Comp-lzo</b>	Configures enable/disable the LZO compression. When the LZO Compression is enabled on the OpenVPN server, you must turn on it at the same time. Otherwise, the network will be abnormal. <i>Default value is YES.</i>
<b>Additional Options</b>	<p>Additional options to be appended to the OpenVPN® config file. Note: Additional options are separated by semicolon.</p> <p><b>For example:</b> comp-lzo no;auth SHA256</p> <p><i>Please use with caution.</i></p> <p>Make sure that the options are supported by OpenVPN® and do not unnecessarily override other configurations above.</p>

*OpenVPN® Settings*

## Advanced Settings

<b>Advanced Network Settings</b>	
<b>DNS Refresh Timer (m)</b>	Configures the refresh time (in minutes) for DNS query. If set to "0", the phone will use the DNS query TTL from the DNS server response.
<b>DNS Failure Cache Duration (m)</b>	Configures the duration (in minutes) of the previous DNS cache when the DNS query fails. If set to "0", the feature will be disabled. Note: Only valid for SIP registration.
<b>Enable LLDP</b>	Enables the LLDP (Link Layer Discovery Protocol) feature on the device. If it is set to "Yes", the device will broadcast LLDP PDU to advertise its identity and capabilities and receive the same from physical adjacent layer 2 peers. The default setting is "Yes".
<b>LLDP TX Interval (s)</b>	<p>Configures the interval the device sends LLDP-MED packet.</p> <p>The default setting is 60s.</p> <p><b>Note:</b> Reboot the device to make changes take effect.</p>
<b>Enable CDP</b>	<p>Configures whether to enable CDP to receive and/or transmit information from/to CDP-enabled devices.</p> <p>The default setting is "No".</p>
<b>Layer 3 QoS for SIP</b>	<p>Defines the Layer 3 packet's QoS parameter for SIP messages in a decimal pattern. This value is used for IP Precedence, Diff-Serv, or MPLS.</p> <p>The default setting is 26 which is equivalent to the DSCP name constant CS6.</p>
<b>Layer 3 QoS for RTP</b>	<p>Defines the Layer 3 packet's QoS parameter for RTP messages in a decimal pattern. This value is used for IP Precedence, Diff-Serv or MPLS.</p> <p>The default setting is 46 which is equivalent to the DSCP name constant CS6.</p>
<b>HTTP/HTTPS User-Agent</b>	<p>Sets the user-agent for contacts.</p> <p><b>Note:</b> Reboot the device to make changes take effect.</p>

<b>SIP User-Agent</b>	Sets the user-agent for SIP. Default is: <ul style="list-style-type: none"> <li>Grandstream GSC3516 \$version</li> </ul>
<b>Proxy</b>	
<b>HTTP Proxy</b>	Specifies the HTTP proxy URL for the phone to send packets to. The proxy server will act as an intermediary to route the packets to the destination
<b>HTTPS Proxy</b>	Specifies the HTTPS proxy URL for the phone to send packets to. The proxy server will act as an intermediary to route the packets to the destination.
<b>Bypass Proxy For</b>	Defines the destination IP address where no proxy server is needed. The device will not use a proxy server when sending packets to the specified destination IP address.

*Network Settings – Advanced Settings*

## System Settings Page Definitions

### Time Settings

<b>NTP Server</b>	Configures the URL or IP address of the NTP server. The phone may obtain the date and time from the server.
<b>Enable Authenticated NTP</b>	Configures whether to enable NTP authentication. If enabled, a cryptographic signature appended to each network packet. If the key is incorrectly configured, the phone will refuse to use the time provided by the NTP server. <i>Default is Disabled</i>
<b>Allow DHCP Option 42 to Override NTP Server</b>	When enabled, DHCP Option 42 will override the NTP server if it is set up on the LAN. <i>Default is Enabled</i>
<b>DHCP Option 2 to Override Time Zone Setting</b>	Allows device to get provisioned for Time Zone from DHCP Option 2 in the local server automatically. <i>Default is Enabled</i>
<b>Time Zone</b>	Specifies the local time zone for the phone. It covers the global time zones and user can selected the specific one from the drop-down list.
<b>Date Display Format</b>	Determines which format will be used to display the date. It can be selected from the drop-down list: <ul style="list-style-type: none"> <li>Normal (YYYY/MM/DD)</li> <li>MM/DD/YYYY</li> <li>DD/MM/YYYY</li> <li>DD, MM YYYY</li> </ul> The default setting is YYYY-MM-DD
<b>Time Display Format</b>	Specifies which format will be used to display the time. It can be selected from 12-hour and 24-hour format.

*Time Settings*

## Security Settings

<b>Web/SSH Access</b>	
<b>Enable SSH</b>	Enables/disables SSH access to the device. The default setting is "Yes".
<b>SSH Port</b>	Customizes the SSH port. By default, SSH uses port 22.
<b>HTTP Web Port</b>	Configures the HTTP port under the HTTP web access mode.
<b>HTTPS Web Port</b>	Configures the HTTPS port under the HTTPS web access mode.
<b>Enable User Web Access</b>	The administrator can disable or enable user web access. This option is set to "No" by default. <b>Note:</b> After first time log in attempt, the user will be forced to change his initial user level password defined by the administrator.
<b>Web Access Mode</b>	Sets the protocol for the web interface.  <ul style="list-style-type: none"> <li>● HTTPS</li> <li>● HTTP</li> <li>● Disabled</li> <li>● Both HTTP and HTTPS</li> </ul> <i>Default is "Both HTTP and HTTPS"</i>
<b>User Login Timeout</b>	Configures login timeout (in minutes) for the user. If there is no activity within the specified time, the user will be logged out, and the Web UI will go to the login page automatically.
<b>Validate Server Certificates</b>	Configures whether to validate the server certificate when downloading the firmware/config file. If set to "Yes", the phone will download the firmware/config file only after the server is validated. Disabled by default.
<b>User Info Management</b>	
<b>User Password</b>	
<b>New Password</b>	Set new password for web GUI access as User. <i>This field is case sensitive.</i>
<b>Confirm Password</b>	Enter the new User password again to confirm.
<b>Admin Password</b>	
<b>Current Password</b>	The current admin password is required to set a new admin password.
<b>New Password</b>	Set new password for web GUI access as Admin. This field is case sensitive.
<b>Confirm Password</b>	Enter the new Admin password again to confirm.
<b>Client Certificate</b>	
<b>Minimum TLS Version</b>	Specifies the minimum TLS version allowed for the connection. <i>Default is TLS 1.0</i>
<b>Maximum TLS Version</b>	Specifies the maximum TLS version allowed for the connection. <i>Default is Unlimited</i>
<b>Enable Weak TLS Cipher Suites</b>	Defines the function for weak TLS cipher suites:  <ul style="list-style-type: none"> <li>● If set to "Enable Weak TLS Cipher Suites", allow users to encrypt data by weak TLS cipher suites</li> </ul>

	<ul style="list-style-type: none"> <li>• If set to "Disable Symmetric Encryption RC4/DES/3DES", allow users to disable weak cipher DES/3DES and RC4.</li> </ul> <p><i>Default is "Enable Weak TLS Cipher Suites"</i></p>
<b>SIP TLS Certificate</b>	The Cert File for the phone to connect to SIP Server via TLS.
<b>SIP TLS Private Key</b>	The Cert Key for the phone to connect to SIP Server via TLS.
<b>SIP TLS Private Key Password</b>	SSL Private key password used for SIP Transport in TLS/TCP.
<b>Custom Certificate</b>	Click on "Upload" to upload a custom certificate. The uploaded custom certificate will be used for SSL/TLS communication instead of the phone default certificate.
<b>Trusted CA Certificates</b>	
<b>Upload/Delete</b>	Click on "Upload" to upload a certificate from our computer or click "Delete" to delete the selected certificate
<b>Load CA Certificates</b>	Phone will verify the server certificate based on the built-in, custom or both trusted certificates list.

*Security Settings*

## Preferences

<b>LED Management</b>	
<b>Enable Missed Call Indicator</b>	If enabled, the LED indicator on the upper right corner of the phone will light up when there is missed call on the phone.
<b>Call Light</b>	Select the LED prompt light during the call. The default light is green.
<b>Volume Settings</b>	
<b>Call Volume</b>	Move the slider to configure call volume
<b>Ringtone Volume</b>	Move the slider to configure ringtone volume
<b>Media Volume</b>	Move the slider to configure media volume
<b>Volume Compensation</b>	If enabled, the volume will be automatically adjusted within an appropriate range according to the ambient noise. Disabled by Default

*Preferences*

## TR-069

<b>Enable TR-069</b>	<p>Sets the device to enable the "CPE WAN Management Protocol" (TR-069). The default setting is "No".</p> <p><b>Note:</b> Reboot the device to make changes take effect.</p>
<b>ACS URL</b>	Specifies URL of TR-069 ACS (e.g, <a href="http://acs.test.com">http://acs.test.com</a> ), or IP address.

<b>ACS Username</b>	Enters username to authenticate to ACS.
<b>ACS Password</b>	Enters password to authenticate to ACS.
<b>Periodic Inform Enable</b>	Sends periodic inform packets to ACS. The default is "No".
<b>Periodic Inform Interval (s)</b>	Configures to send periodic "Inform" packets to ACS based on a specified intervals. The default setting is 86400.
<b>Connection Request Username</b>	Enters username for the ACS to connect to the device.
<b>Connection Request Password</b>	Enters the password for the ACS to connect to the device.
<b>Connection Request Port</b>	Enters the port for the ACS to connect to the device.
<b>CPE Cert File</b>	Uploads Cert File for the device to connect to the ACS via SSL.
<b>CPE Cert Key</b>	Uploads Cert Key for the device to connect to the ACS via SSL.

TR-069

## Sensor Settings

<b>Basic Settings</b>	
<b>Basic Settings</b>	
<b>Sensor Type</b>	Set the initial state of the sensor, when the selection is normally open, the contact is disconnected when static; When the selection is normally closed, the contact is connected when static. The normally open will be connected when the electrical action is on the switch, and the normally closed will disconnected. The default is normally open.
<b>Trigger Type</b>	Set the type of the trigger mode, and when the selection is level triggered, only high level (1) or low level (0) will trigger the notification. When the edge trigger is selected, the notification is triggered only when the level changes (high level to low level, or low level to high level). The default is level trigger.
<b>Trigger time</b>	
<b>Cycle Time</b>	The alarm can be configured to be triggered all days of the week, in this case "All days" option needs to be checked. Or to some specific schedule, in this case "Period of Time" option needs to be checked for users to be able to configure Time and Frequency options below.
<b>Time</b>	Set the activation time, up to 3 times. When the activation time is not set, the default time is full day.
<b>Frequency</b>	Set the activation frequency from Monday to Sunday, which can be selected from the whole week. The default value is not selected.
<b>Play Audio</b>	Play a sound when the switch is triggered during the scheduled time.
<b>Prompt Tone</b>	When the "voice prompt" is selected, you can upload the customized audio by clicking on "Upload" and choose the file.

<b>Make Call</b>	Dial the number when the sensor is activated.
<b>Dial out extension</b>	Enter the number you need to dial and click the “add” button to set two numbers at the same time.
<b>Hang up</b>	Hang up calls when the sensor is triggered, such as SIP call, multicast, etc. When checked at the same time as Make Call, if there is currently a call, the first trigger will hang up the call, and the second trigger will dial.

*Sensor Settings*

## Alarm in Settings

**Note**

The Alarm-in feature is available only on the GSC3506 and GSC3506 V2 Models

<b>Trigger time</b>	
<b>Cycle Time</b>	Configures the cycle time. If set to "Daily", it will trigger the function every day. If set to "Period of time", it will trigger the function according to the set time period. The default value is "Daily".
<b>Time</b>	Set the activation time, up to 3 times. When the activation time is not set, the default time is full day.
<b>Frequency</b>	Set the activation frequency from Monday to Sunday, which can be selected from the whole week. The default value is not selected.
<b>Play Audio</b>	Play a sound when the switch is triggered during the scheduled time.
<b>Prompt Tone</b>	When the “voice prompt” is selected, you can upload the customized audio by clicking on “Upload” and choose the file.
<b>Make Call</b>	Dial the number when the sensor is activated.
<b>Dial out extension</b>	Enter the number you need to dial and click the “add” button to set two numbers at the same time.

*Alarm in settings*

## Backup/Restore

The Backup/Restore page is used to back up data or import backup files to restore data. Users can start the Backup by clicking on “Backup”.

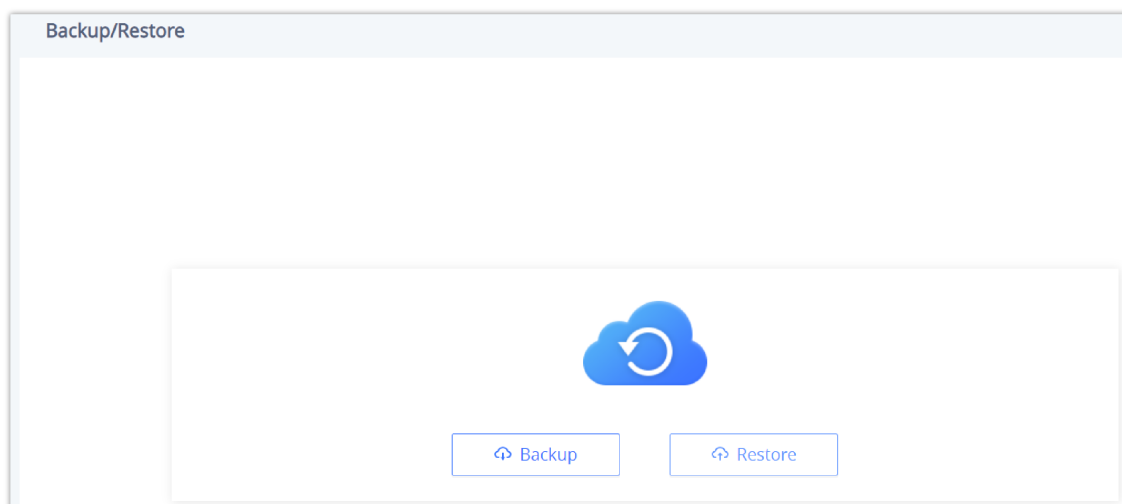



## Maintenance Page Definitions

### Upgrade and Provisioning

#### Upgrade and Provisioning/Firmware

Upgrade via Manually Upload	
Upload Firmware File to Update	Allows users to load the local firmware to the device to update the firmware.
Upgrade via Network	
Firmware Upgrade via	Configures firmware upgrade method as TFTP, HTTP, HTTPS, FTP or FTPS. <i>Default is HTTP</i>
Firmware Server Path	Sets IP address or domain name of firmware server. The URL of the server that hosts the firmware release. <i>Default is "fm.grandstream.com/gs".</i>
Firmware Server Username	The username for the firmware server.
Firmware Server Password	The password for the firmware server.
Firmware File Prefix	Checks if firmware file is with matching prefix before downloading it. This field enables user to store different versions of firmware files in one directory on the firmware server.
Firmware File Postfix	Checks if firmware file is with matching postfix before downloading it. This field enables user to store different versions of firmware files in one directory on the firmware server.
Upgrade Detection	
Upgrade	Click the "Start" button to check whether the firmware in the firmware server has an updated version, if so, update immediately.

#### Upgrade and Provisioning – Firmware page

#### Upgrade and Provisioning/Config File

Configure Manually	
Download Device Configuration	Click to download the device configuration file in .txt format.
Upload Device Configuration	Upload config file to the phone.
Configure via Network	
Config Upgrade via	Configures the config upgrade method as TFTP, HTTP, HTTPS, FTP or FTPS. <i>Default is HTTPS</i>
Config Server Path	Sets IP address or domain name of configuration server. The server hosts a copy of the configuration file to be installed on the device. <i>Default is "fm.grandstream.com/gs".</i>
Config Server Username	The username for the config server.

<b>Config Server Password</b>	The password for the config server.
<b>Config File Prefix</b>	Checks if configuration files are with matching prefix before downloading them. This field enables user to store different configuration files in one directory on the provisioning server.
<b>Config File Postfix</b>	Checks if configuration files are with matching postfix before downloading them. This field enables user to store different configuration files in one directory on the provisioning server.
<b>Authenticate Conf File</b>	Sets the device to authenticate configuration file before applying it. When set to "Yes", the configuration file must include value P1 with phone system's administration password. If it is missed or does not match the password, the device will not apply it. <i>Default setting is "No"</i> .
<b>XML Config File Password</b>	Decrypts XML configuration file when encrypted. The password used for encrypting the XML configuration file is using OpenSSL.

*Upgrade and Provisioning – Config File page*

### Upgrade and Provisioning/Provision

<b>Auto Upgrade</b>	
Automatic Upgrade	<p>Specifies when the firmware upgrade process will be initiated; there are 4 options:</p> <ul style="list-style-type: none"> <li>● <b>No:</b> The device will only do upgrade once at boot up.</li> <li>● <b>Yes, check for upgrade periodically:</b> User needs to specify an Interval (m) and Hour of the Day (0-23).</li> <li>● <b>Check every day:</b> User needs to specify "Hour of the day (0-23)".</li> <li>● <b>Check every week:</b> User needs to specify "Hour of the day (0-23)" and "Day of the week (0-6)".</li> </ul> <p><i>Note: Day of week is starting from Sunday. The default setting is "No"</i>.</p>
Start Upgrade at Random Time	Configures whether the phone will upgrade automatically at a random time within the configured time interval.
Firmware Upgrade and Provisioning	<p>Defines the device's rules for automatic upgrade. It can be selected from:</p> <ul style="list-style-type: none"> <li>● Always Check for new firmware</li> <li>● Check new firmware only when F/W pre/suffix changes,</li> <li>● Always skip the Firmware Check.</li> </ul> <p><i>The default setting is "Always Check for new firmware"</i>.</p>
<b>DHCP Option</b>	
Allow DHCP Option 43 and Option 66 to Override Server	<ul style="list-style-type: none"> <li>● If set to "Yes" on the LAN side, the phone will reset the CPE, upgrade, network VLAN tag and priority configuration according to option 43 sent by the server. At the same time, the upgrade mode and server path of the configuration upgrade mode will be reset according to option 66 sent by the server</li> <li>● If set to "Prefer, fallback when failed", the phone can fallback to use the configured provisioning server under its Firmware and Config server path in case the server from DHCP Option fails.</li> </ul> <p><i>The default setting is "Yes"</i>.</p>
Allow DHCP Option 120 to Override SIP Server	Configures the device to allow the DHCP offer message to override the Config Server Path via the Option 120 header. <i>The default setting is "Disabled"</i> .
Additional Override DHCP Option	<p>Configures additional DHCP Option to be used for firmware server instead of the configured firmware server or the server from DHCP Option 43 and 66. This option will be effective only when "Allow DHCP Option 43 and Option 66 to Override Server" is enabled. There are 3 options:</p> <ul style="list-style-type: none"> <li>● None</li> </ul>

	<ul style="list-style-type: none"> <li>• Option 150</li> <li>• Option 160</li> </ul> <p><i>The default setting is "Option 150"</i></p>
Allow DHCP Option 242 (Avaya IP Phones)	Enables DHCP Option 242. Once enabled, the device will use the configuration info issued by the local DHCP in Option 242 to configure proxy, transport protocol and server path. <i>The default setting is "Disabled"</i> .
<b>Config Provision</b>	
Config Provision	Device will download the configuration files and provision by the configured order. Use arrow buttons to add and order configuration files.
Download and Process All Available Config Files	By default, the device will provision the first available config in the order of cfgMAC, cfgMAC.xml, cfgMODEL.xml, and cfg.xml (corresponding to device specific, model specific, and global configs). If set to "Yes", the device will download and apply (override) all available configs in the order of cfgMAC, cfg.xml, cfgMODEL.xml, cfgMAC.xml.
3CX Auto Provision	If enabled, the phone will send SUBSCRIBE requests to the multicast address in LAN during bootup for automatic provisioning. This feature requires 3CX server support. <i>Default setting is "Enabled"</i> .

*Upgrade and Provisioning – Provision page*

### Upgrade and Provisioning/Advanced Settings

<b>Send HTTP Basic Authentication By Default</b>	Determine whether to send basic HTTP authentication information to the server by default when using wget to download firmware or config file. If set to "Yes", send HTTP/HTTPS user name and password no matter the server needs authentication or not. If set to "No", only send HTTP/HTTPS user name and password when the server needs authentication. <i>The default value is "Disabled"</i> .
<b>Enable SIP NOTIFY Authentication</b>	Device will challenge NOTIFY with 401 when set to "Yes". <i>The default value is "Enabled"</i> .
<b>Validate Hostname in Certificate</b>	Configures to validate the hostname in the SSL certificate. <i>The default value is "Disabled"</i> .
<b>Allow AutoConfig Service Access</b>	Set to allow access to the AutoConfig service. If not checked, access to service.ipvideotalk.com will be disabled. <i>The default value is "Enabled"</i> .
<b>Factory Reset</b>	Resets the device to the default factory setting mode by clicking on "Start button".

*Upgrade and Provisioning – Advanced Settings page*

### System Diagnosis

<b>Syslog</b>	
<b>Syslog Protocol</b>	<p>Select the transport protocol over which log messages will be carried.</p> <ul style="list-style-type: none"> <li>• <b>UDP:</b> Syslog messages will be sent over UDP.</li> <li>• <b>SSL/TLS:</b> Syslog messages will be sent securely over TLS connection.</li> </ul>
<b>Syslog Server</b>	The URL/IP address for the syslog server.

<b>Syslog Level</b>	<p>Selects the level of logging for syslog. There are 4 levels from the dropdown list: DEBUG, INFO, WARNING and ERROR. The following information will be included in the syslog packet:</p> <ul style="list-style-type: none"> <li>● <b>DEBUG:</b> Sent or received SIP messages.</li> <li>● <b>INFO:</b> Product model/version on boot up, NAT related info, SIP message summary, Inbound and outbound calls, Registration status change, negotiated codec, Ethernet link up</li> <li>● <b>WARNING:</b> SLIC chip exception.</li> <li>● <b>ERROR:</b> SLIC chip exception, Memory exception.</li> </ul> <p><b>Note:</b> Changing syslog level does not require a reboot to take effect. <i>The default setting is "None".</i></p>
<b>Syslog Keyword Filter</b>	<p>Only send the syslog with keyword, multiple keywords are separated by comma. Example: set the filter keyword to "SIP" to filter SIP log.</p>
<b>Send SIP Log</b>	<p>Configures whether the SIP log will be included in the syslog messages. <i>Default is "Disabled"</i></p>
<b>Packet Capture</b>	
<b>With RTP Packets</b>	<p>Configures whether the packet capture file contains RTP or not. <i>Then click "Start" to start Packet Capture or "Stop" to stop the Packet Capture.</i></p>
<b>With Secret Key Information</b>	<p>Configures whether the packet capture file contains secret key information or not. <i>Then click "Start" to start Packet Capture or "Stop" to stop the Packet Capture.</i></p>
<b>Ping</b>	
<p>Enter the URL into the textbox then click "Start" to begin the ping, Results will be shown below.</p>	
<b>Traceroute</b>	
<p>Enter the URL into the textbox then click "Start" to begin the Traceroute, Results will be shown below.</p>	
<b>Remote Diagnostics</b>	
<p>When enabled, this device will allow remote access and remote collection of logs. It will automatically end when it expires. <i><b>Note:</b> Click on "Start", then the Access Address and Expiration Time will be shown below.</i></p>	

*System Diagnostics page*

## Event Notification

Set the URL for events on the phone web GUI, and when the corresponding event occurs on the device, the device will send the configured URL to the SIP server. The dynamic variables in the URL will be replaced by the actual values of the device before sending it to the SIP server, in order to achieve the purpose of events notification. Here are the standards:

1. The IP address of the SIP server needs to be added at the beginning and separate the dynamic variables with a "/".
2. The dynamic variables need to have a "\$" at the beginning. For example: local=\$local
3. If users need to add multiple dynamic variables in the same event, users could use "&" to connect with different dynamic variables. For example: 192.168.40.207/mac=\$mac&local=\$local
4. When the corresponding event occurs on the device, the device will send the MAC address and phone number to the server address 192.168.40.207.

<b>Phone Status</b>
---------------------

<b>Bootup Completed</b>	Configures the event URL when phone boots up.
<b>Registered</b>	Configures the event URL when an account in the device is registered successfully.
<b>Unregistered</b>	Configures the event URL when an account in the device is unregistered.
<b>Call Operation</b>	
<b>Incoming Call</b>	Configures the event URL when phone has an incoming call.
<b>Outgoing Call</b>	Configures the event URL when phone has an outgoing call.
<b>Missed Call</b>	Configures the event URL when the device has new a missed call.
<b>Established Call</b>	Configures the event URL when a call is established.
<b>Terminated Call</b>	Configures the Action URL to send when phone terminates a call.
<b>Log On</b>	Configures the event URL when users log on the device successfully.
<b>Log Off</b>	Configures the event URL when users log off the device.

*Event Notification*

## Application Page Definitions

### Music

<b>Playback</b>	
<b>Audio File</b>	<p>Please select the audio file type:</p> <ul style="list-style-type: none"> <li>• <b>RTSP stream:</b> Set up the stream's RTSP address, in order to play online music, it supports playing audio files in .ts (.mp3) format. For example rtsp://ip_address/musicFile.ts.</li> <li>• <b>Local Music:</b> choose locally from your computer the music to play.</li> <li>• <b>Online Music:</b> Stream online music from the web or from a 3rd party desktop music streaming software.</li> </ul>
<b>RTSP stream address</b>	<p>Supports RTSP stream address to obtain audio Ex : (rtsp://[IP]:[port]/[audio file name]), supporting MP3 and TS formats.</p>
<b>Local Music</b>	<p>Displays the audio tracks uploaded to the cloud. It Supports .mp3 and .ogg audio formats only.</p>
<b>Share Music</b>	<p>Prompts a popup browser tab or window from which the music will be streamed, play music on PC first, and click to select the music window to be shared to the GSC. It is recommended to use the browser Chrome (72 and above), Edge (79 and above), Otherwise it may be silent after sharing.</p>
<b>Timed playback</b>	
Click on "Add rule" to create Timed playback rule	
<b>Timed playback rule</b>	
<b>Audio File</b>	Please select the audio file type

<b>RTSP stream address / Local Music</b>	<p><b>If RTSP stream is selected:</b> Support RTSP stream address to obtain audio(rtsp://[IP]:[port]/[audio file name]), supporting MP3 and TS formats.</p> <p><b>If Local Music is selected:</b> Please select local music, supporting MP3 and OGG formats.</p>
<b>Play Mode</b>	<ul style="list-style-type: none"> <li>• <b>Single play:</b> play the music once at the set time.</li> <li>• <b>Loop play:</b> play music in a loop within the set time.</li> </ul>
<b>Play interval (s)</b>	Configure the interval between the two playbacks. the valid range is 0-1800 seconds. The Default value is 10 seconds.
<b>Play Time</b>	Set the trigger time, up to 3 items can be set. Click on "+" to add more
<b>Frequency</b>	Configures the activation frequency from Monday to Sunday. Up to 7 days can be selected. <i>Default value is not selected.</i>

*Music*

## Playback Cascade

<b>Playback Cascade</b>	
<b>Cascade role</b>	
Select the cascade role. Only cascading on the same network segment is supported and only one Master is allowed. You can set the cascade role to either "Slave", "Master", or "None", By Default, it is set to "Slave".	
<b>Multicast Address</b>	In the case of a Master Cascade role, Enter the multicast address and port. As the Master, multicast will be initiated by this address. As the Slave, it will automatically obtain the address initiated by the Master.
<b>Forwarding Category</b>	This options selects the type of audio to forward. it can be Music Media , call or alarm.
<b>Trigger Time</b>	
Gives the option to add a triggering time for the Playback	
<b>Playback time</b>	Configures the activation time. Up to 3 entries can be configured. When the activation time is not set, the default time is a full day.
<b>Frequency</b>	Configures the activation frequency from Monday to Sunday. Up to 7 days can be selected. The default value is not selected.

*Playback Cascade*

## GSC Assistant

<b>GSC Assistant</b>	
<b>Managed by GSC Assistant App</b>	Configures the ability for the device to be detectable by the GSC Assistant App. Enabled by Default.
<b>Device Label</b>	Defines under what label the GSC shows up during the scan.

## Diagnostic Page Definitions

### Audio Loop Test

An audio loop test is used to test the MICs. Each one of the MICs is tested separately.

#### Note

The following feature is available on the GSC3516 only

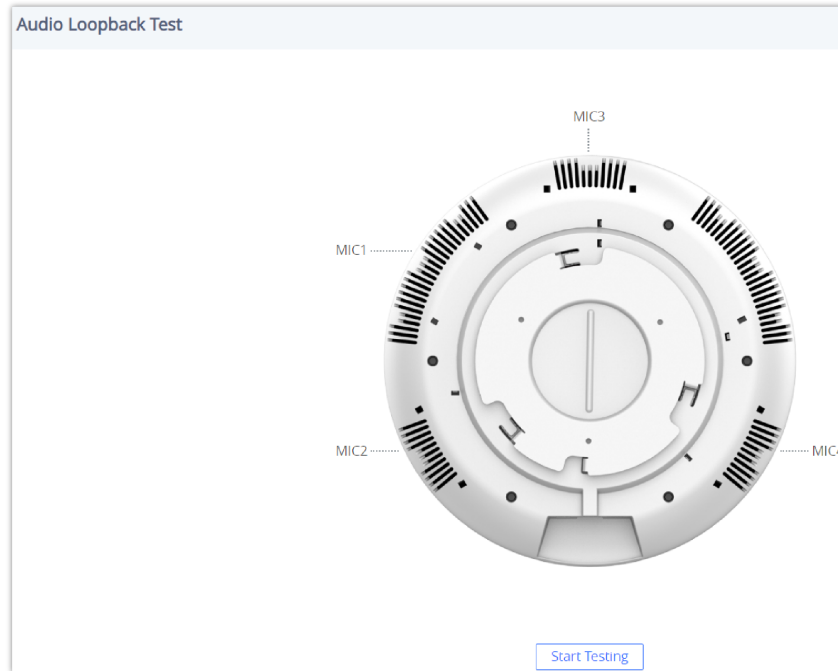

*Diagnostic – Audio Loop Test*

### Built-in Speaker Test

Built-in Speaker Test is used to test the devices by playing a piece of music in order to verify the sound quality.

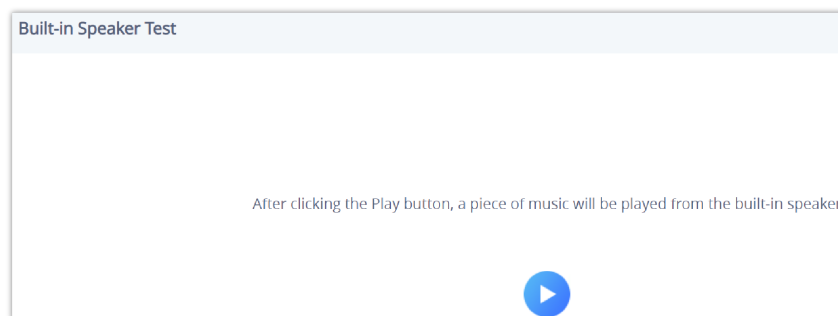

*Built-in Speaker Test*

### Volume Key Test

#### Note

The volume Key test is available only on the GSC3506 and GSC3506 V2 Speaker Model

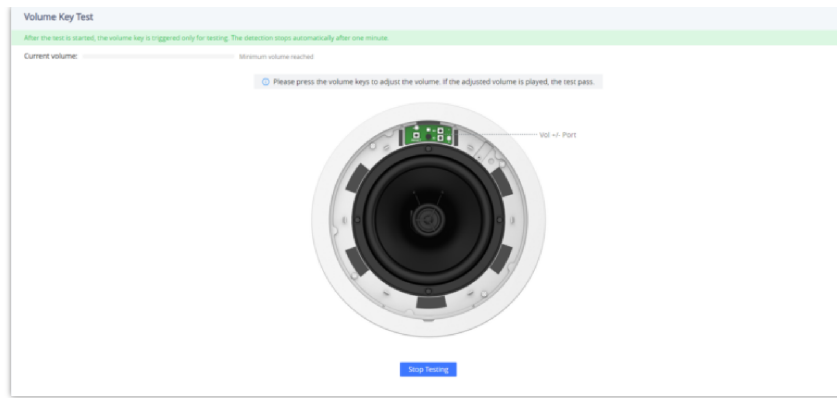

GSC3506 Volume Test

## LED Test

The LED Test is used to test the availability of the four colored LEDs and their intensity. The colors of LEDs available are Green, Red, Blue, and White.



GSC3516 LED Test

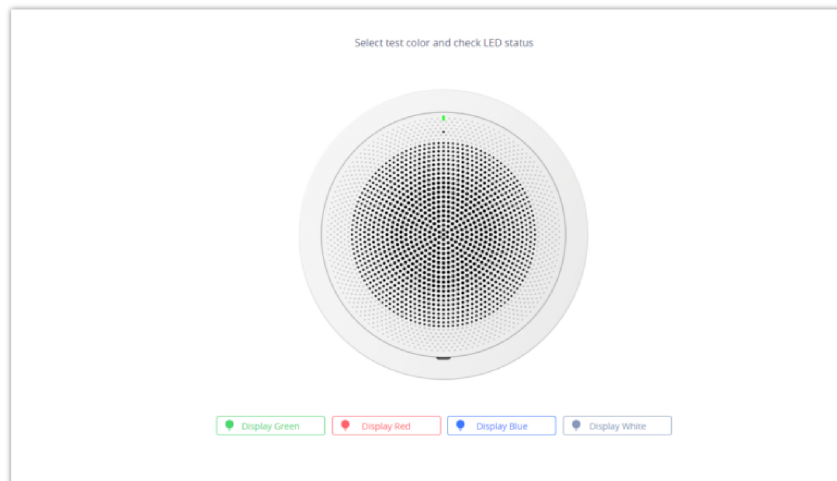

GSC3506 LED Test

## Certificate Verify

Certificate Verify is used to test the validity of the existing certificate.



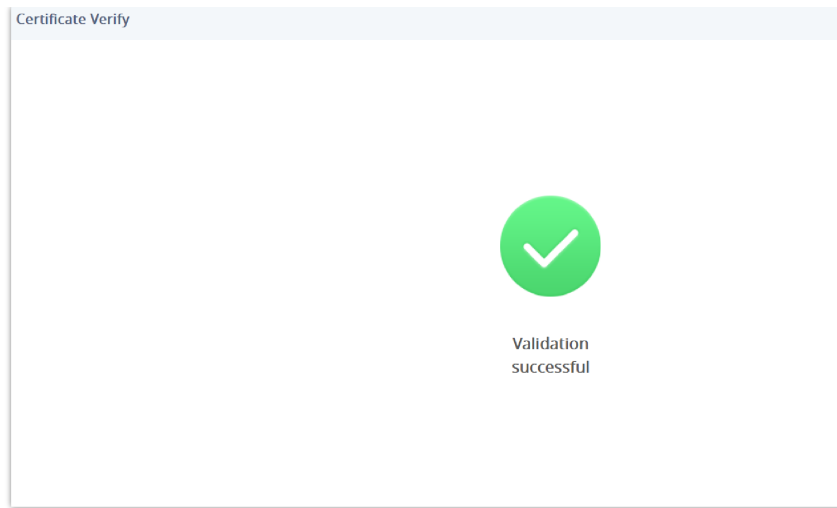

*Certificate Verify*

## Reset Button Test

Reset Button Test is used to test the Reset button, during the test the reset button doesn't trigger a factory reset, this feature allows the user to check if the button is responding.

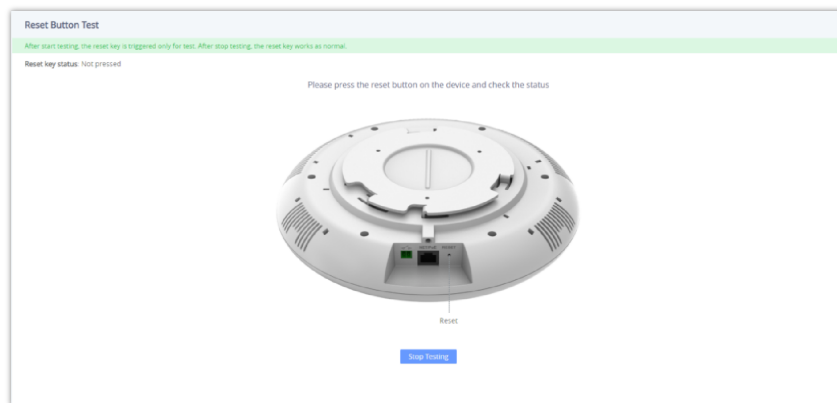

*GSC3516 Reset Button Test*

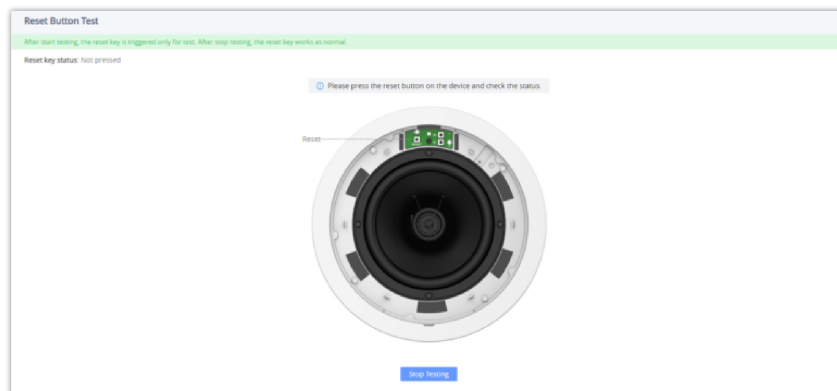

*GSC3506 Reset Button Test*

## Sensor Detection

Click on "Start Testing" [Start Testing](#) to start the testing for the 2-PIN Port.



*Sensor Detection for the GSC3516*

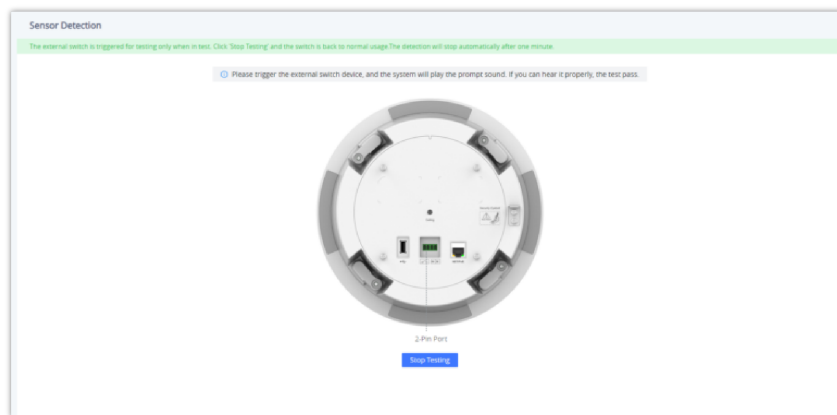

*Sensor Detection for the GSC3506*

## Alarm in Test

### Note

This Test feature is available only on the GSC3506 and GSC3506 V2 Speaker Model

Click on "Start Testing" [Start Testing](#) to start the testing for the Alarm in test.

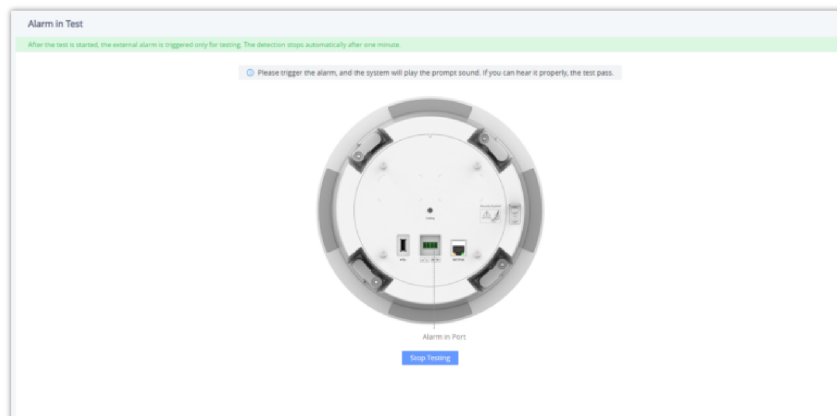

*Alarm-in Test for the GSC3506*

## USB Test

### Note

This Test feature is available only on the GSC3506 and GSC3506 V2 Speaker Model

Click on "Start Testing" **Start Testing** to start the testing for the USB Test.

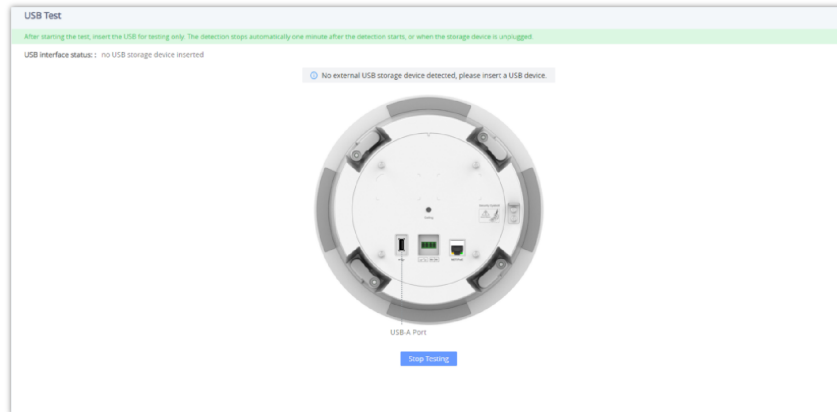

USB Test for the GSC3506

## Factory Reset

To perform a factory reset via the Web GUI, Navigate to **Diagnostic** → **Factory Reset**, click on the "Factory Reset" button then click on "OK" to confirm the factory reset.

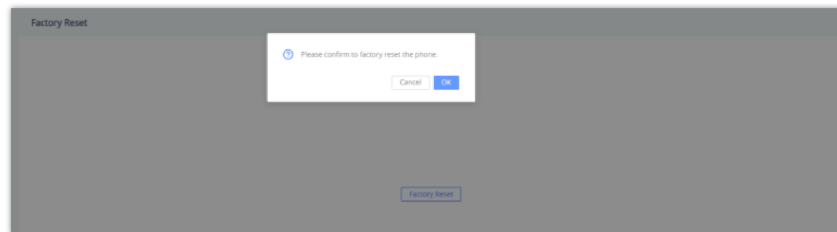

Factory reset via web GUI for GSC35x6 (V2)

## EXPERIENCING THE GSC35x6 (V2)

Please visit our website: <https://www.grandstream.com> to receive the most up-to-date updates on firmware releases, additional features, FAQs, documentation, and news on new products.

We encourage you to browse our [product-related](#) documentation, FAQs, and [User and Developer Forum](#) for answers to your general questions. If you have purchased our products through a Grandstream Certified Partner or Reseller, please contact them directly for immediate support.

Our technical support staff is trained and ready to answer all of your questions. Contact a technical support member or [submit a trouble ticket online](#) to receive in-depth support.

Thank you again for purchasing Grandstream SIP Speaker, it will be sure to bring convenience and color to both your business and personal life.

## CHANGE LOG

This section documents significant changes from previous versions of the user manual for the GSC35XX Series. Only major new features or major document updates are listed here. Minor updates for corrections or editing are not documented here.

### Firmware Version 1.0.5.8

Product name: GSC3506, GSC3516

- Added ability to enable/disable "User" web access. [[ENABLE USER WEB ACCESS](#)]
- Disabled the "User" Web UI account by default. [[ENABLE USER WEB ACCESS](#)]
- Added a prompt to change password when logging in to account "User" for the first time [[Enable User Web Access](#)]

### **Firmware Version 1.0.5.7**

*Product name:* GSC3506, GSC3516

- Added ability to disable start and end of multicast tones. [[Multicast Tone](#)] [[End-Call Tone](#)]
- Added ability to change the LED color for calls during an active call. [[Call Light](#)]

### **Firmware Version 1.0.5.4**

*Product name:* GSC3506, GSC3516

- Added pvalue support on the alias template to support UCM Zero Config custom parameters. [[Download Device Configuration](#)]
- Added support for RTP timeout. [[RIP TIMEOUT](#)]
- Added the ability to change the web login timeout value. [[WEB LOGIN TIMEOUT](#)]

### **Firmware Version 1.0.3.8**

*Product name:* GSC3506, GSC3516

- Added support for GSC Assistant. [[GSC ASSISTANT](#)]

### **Firmware Version 1.0.3.4**

*Product name:* GSC3506, GSC3516

- Remove the start and end of multicast tones. [[Multicast](#)]

### **Firmware Version 1.0.1.29**

*Product name:* GSC3516

- This is the initial version.

### **Firmware Version 1.0.1.13**

*Product name:* GSC3506

- This is the initial version.